

NEWS
0 1 9

antoniolupi

MADE IN ITALY

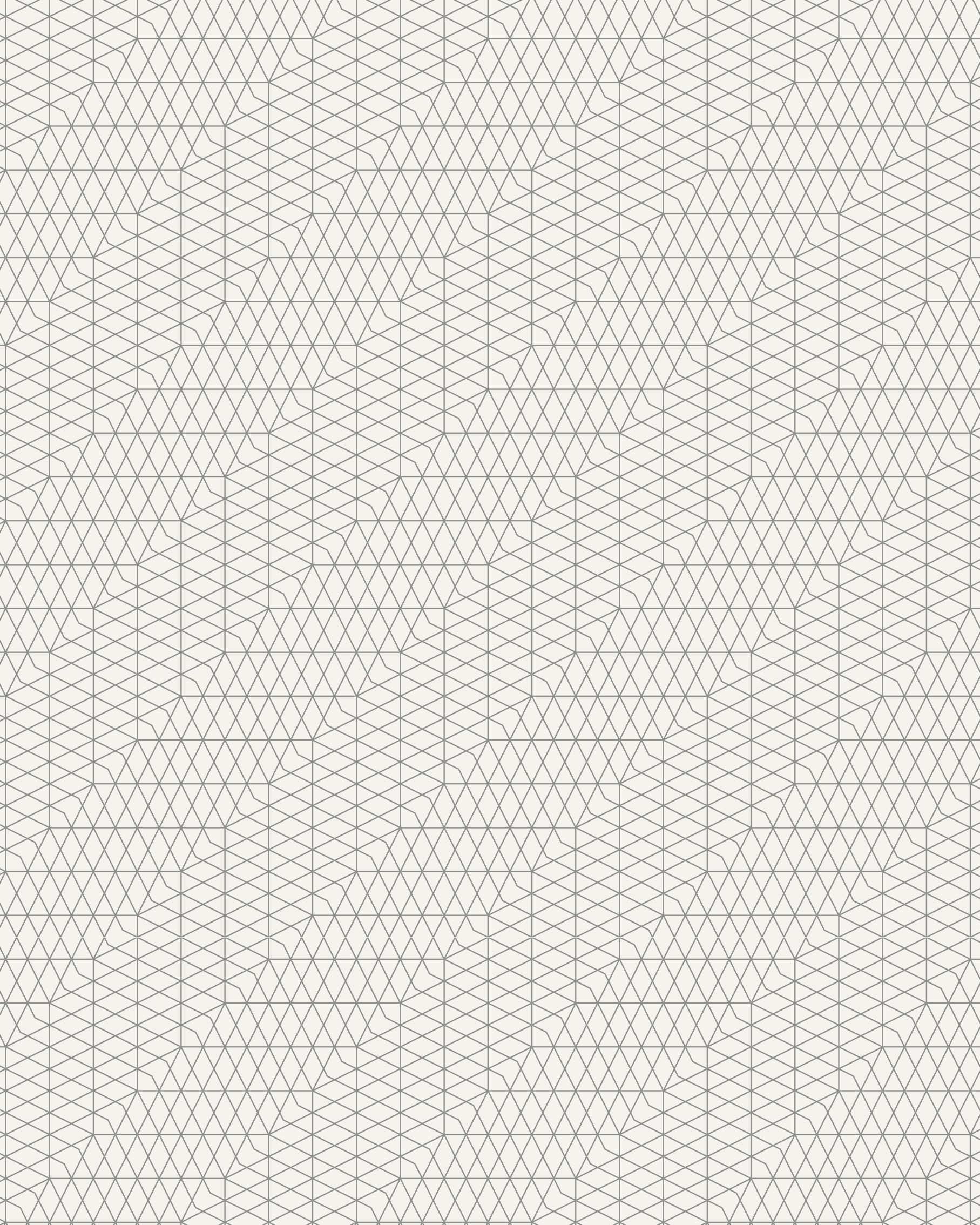

CATALOGO NEWS
0 1 9

L'eccellenza nel bagno ha un'anima toscana
Excellence in the bathroom has a Tuscan soul

antoniolupi

MADE IN ITALY

NUOVE LACCATURE

NEW LACQUERED COLORS

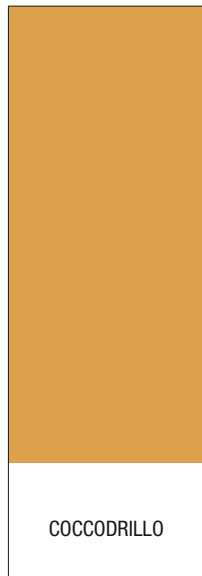

COCCODRILLO



KAJAL



VINO



MIRTO



POMPEIANO



VENEZIANO

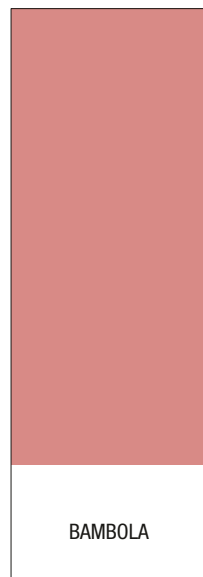

BAMBOLA



ANATRA



VESPA



LAMBRETTA



ALGA



ERA GLACIALE



RANA BLU

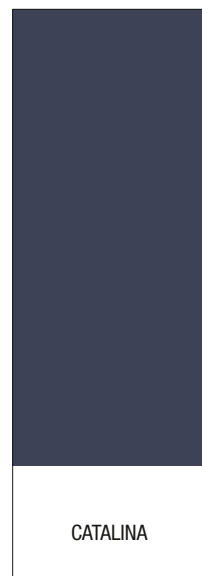

CATALINA



PROFONDO BLU

4 - 11

NUOVE LACCATURE / *NEW LACQUERED COLORS*

12 - 17

SANITARI / *SANITARY-WARE*

18 - 37

TOP / TOPS

38 - 61

LAVABI / *SINKS*

62 - 79

LAVABI / *SINKS* / FREESTANDING

80 - 97

CRISTALMOOD

98 - 115

VASCHE / TUBS

116 - 137

SOFFIONI / OVERHEAD SHOWERS

138 - 167

RUBINETTERIA / TAPS

168 - 179

ILLUMINAZIONE E SPECCHIERE / LIGHTING AND MIRRORS

180 - 189

ACCESSORI / ACCESSORIES



8 strati di
verniciatura
*8 coats of
paint*

1 polyester
2 polyester
3 vernice / *paint*
4 vernice / *paint*

1 polyester
2 polyester
3 vernice / *paint*
4 vernice / *paint*

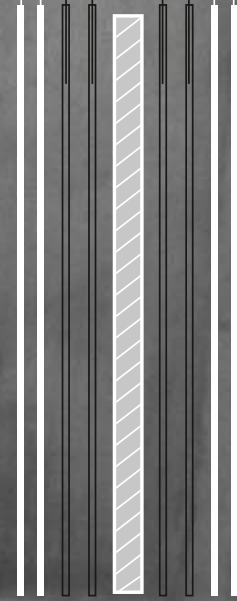

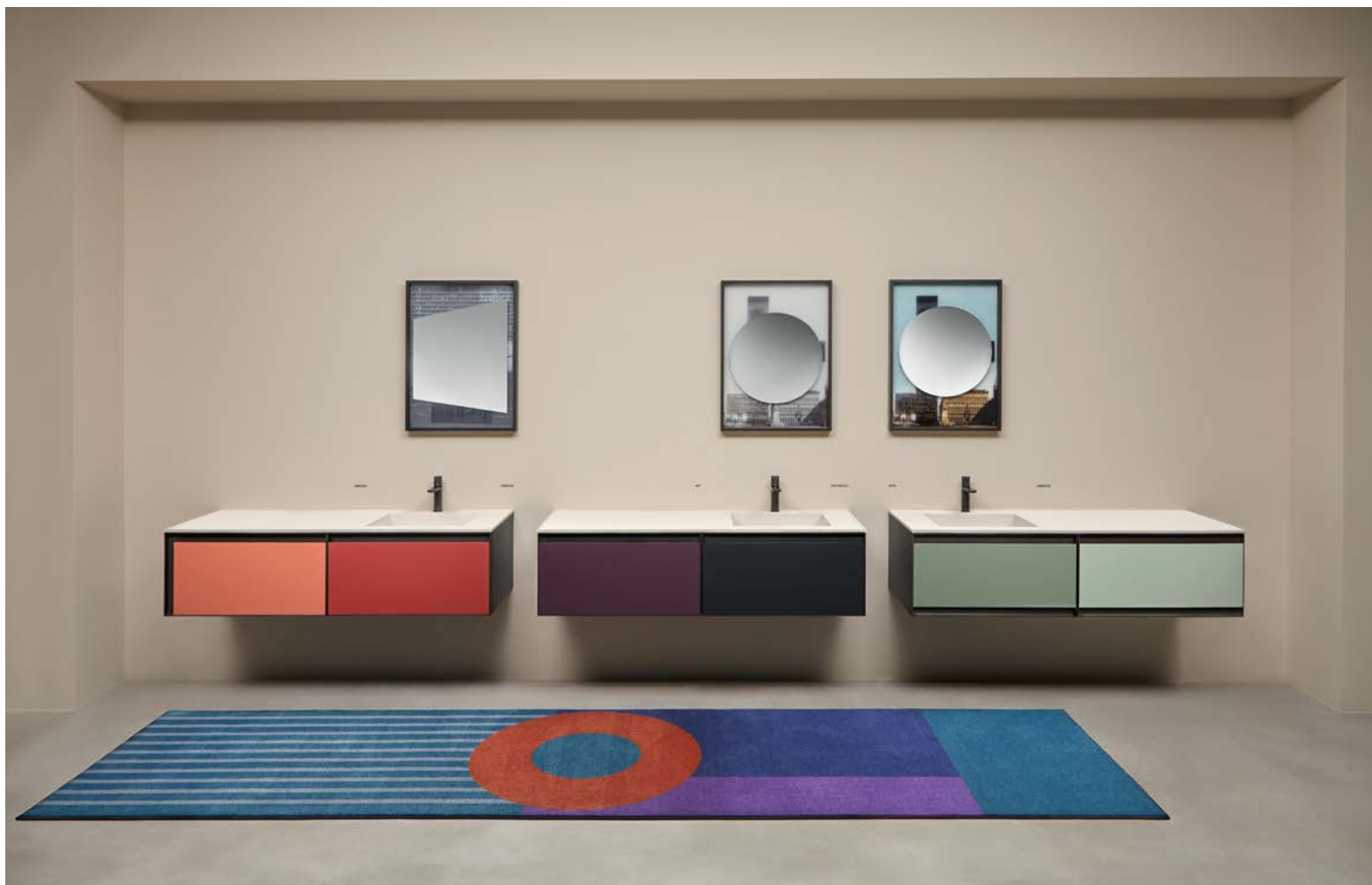

NUOVE LACCATURE

Nuance di tendenza, colori sofisticati ed eleganti che permettono di dar vita a raffinate composizioni e ad accostamenti cromatici ricercati. antoniolupi ha messo a punto una palette inedita composta da quindici nuove laccature disponibili nella finitura opaco, goffrato e lucido. Quindici colori per interpretare il mood dell'interior design contemporaneo, dalle tonalità calde a quelle più fredde, perfette per esaltare i volumi e dare profondità alle geometrie delle collezioni di mobili.

NEW LACQUERED COLORS

Trendy nuances, sophisticated and elegant colors that allow you to create refined compositions and sophisticated color combinations. antoniolupi has developed an unprecedented palette made up of fifteen new lacquers available in matt, embossed and glossy finish. Fifteen colors to interpret the mood of contemporary interior design, from warm to cooler colors perfect for enhancing volumes and giving depth to the geometry of furniture collections.





ATELIER





Verniciabile in tutti i colori del nostro campionario
Can be lacquered in all colors of our collection



SISTEMA "LESS_RING" / "LESS_RING" FLUSHING SYSTEM

Il vaso in ceramica della collezione Komodo, utilizza il sistema LESS_RING che oltre a garantire una perfetta pulizia del volume interno e massima capacità di sciacquo, dona all'insieme un'immagine finale gradevole. Il movimento circolare consente di lavare in modo preciso e senza spruzzi tutta la superficie, contrariamente a quanto avveniva con i normali vasi con la brida, per un'igiene del 100%.

The ceramic water closet, from the Komodo collection, uses the LESS_RING system that ensures perfect internal cleaning and a maximum ability to rinse. The circular movement allows to wash in a precise manner and without splashing, contrary to what happens with standard water closets with a rim, to assure 100% hygiene.

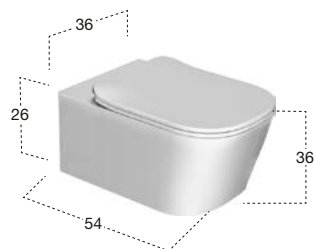

H	P	L	art.	
26	54	36	KOMODO1	Ceramica Lucida / High gloss Ceramic
26	54	36	KOMODO3	Ceramica Satinata / Satin Ceramic

Vaso in ceramica lucida o satinata, sospeso con scarico a parete e sistema senza brida, completo di sedile FLAT con sistema di sganciamento rapido, realizzato in resina termoindurente con chiusura rallentata "soft-close".

High gloss or satin suspended ceramic water closet with wall drain and washdown rimless flushing, complete with seat and cover FLAT made of thermosetting resin, quick release system and soft closing hinges.







H	P	L	art.
66	8	33	INTENSO

Doccetta igienica da incasso in acciaio inox satinato o lucido AISI 304, con doppio sistema di apertura e chiusura acqua e flessibile 85 cm, con getto nebulizzato.

Encased hygienic shower in satin or polished stainless steel AISI 304, with double opening and closing water system and high pressure flexible hose 85 cm, with nebulized jet.



H	P	L	art.
66	8	33	TENSO

Idroscopino da incasso in acciaio inox satinato o lucido AISI 304, con doppio sistema di apertura e chiusura acqua e flessibile 85 cm ad alta pressione.

Encased hydrobrush cleaner in satin or polished stainless steel AISI 304 with double opening and closing water system and high pressure flexible hose 85 cm.

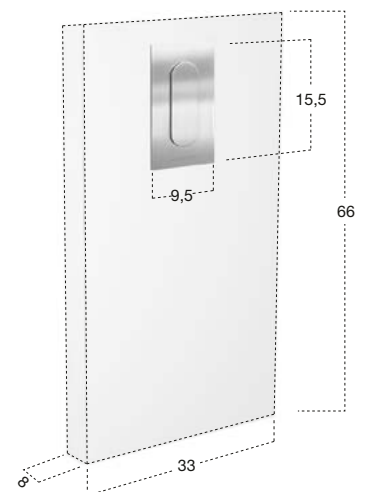

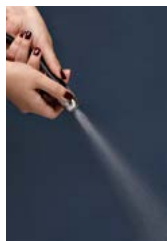
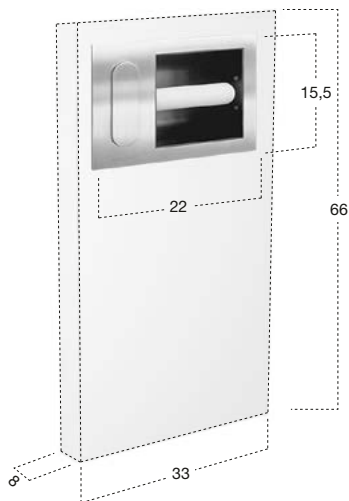

H	P	L	art.
66	8	33	CARTAITENSO

Porta carta e doccetta igienica da incasso in acciaio inox satinato o lucido AISI 304 con doppio sistema di apertura e chiusura acqua e flessibile 85 cm, con getto nebulizzato.

Encased hygienic shower and paper roll holder in satin or polished stainless steel AISI 304 with double opening and closing water system and flexible hose 85 cm, with nebulized jet.



H	P	L	art.
66	8	33	CARTAITENSO

Porta carta e idroscopino da incasso in acciaio inox satinato o lucido AISI 304 con doppio sistema di apertura e chiusura acqua e flessibile di 85 cm ad alta pressione.

Encased hydrobrush cleaner and paper roll holder in satin or polished stainless steel AISI 304 with double opening and closing water system and high pressure flexible hose 85 cm.



P	L	art.
9	6,5	GIRO_INTENSO

Doccetta igienica in acciaio inox satinato AISI 316/L con apertura acqua (2), supporto con chiusura integrata di sicurezza (1) e flessibile 100 cm, con getto nebulizzato.

Hygienic shower with nebulizer jet in satin stainless steel AISI 316/L, water opening system (2), support with integrated security closure (1) and hose 100 cm.

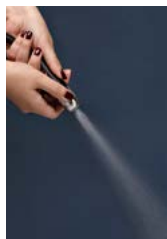

P	L	art.
9	6,5	GIRO_SCHIZZO

Idroscopino in acciaio inox satinato AISI 316/L con apertura acqua (2), supporto con chiusura integrata di sicurezza (1) e flessibile 100 cm ad alta pressione.

Satin stainless steel AISI 316/L hydrobrush with water opening system (2), support with integrated security closure (1) and high pressure hose 100 cm.

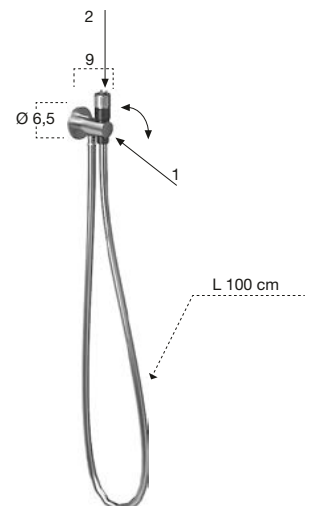

QUARZOMOOD

Insieme al Flumood, l'innovativo materiale composto per la maggior parte da idrossido di alluminio e resine sintetiche, frutto della ricerca antioniolupi, l'azienda propone dopo due anni di sperimentazioni il Quarzomood che oltre alla grandissima resistenza dovuta all'aggiunta di quarzo, consente nuove cromie. L'azienda ne ha sviluppate tre, denominate Serena, Terra e Seta che permettono ricercati accostamenti dei piani e dei lavabi integrati, sia con le nuove finiture dei mobili, sia con le versioni laccate e uniformi.

Resistentissimo, facile da pulire, ripristinabile agevolmente in caso di graffi, bruciature o dall'usura dell'impiego quotidiano, Quarzomood mantiene inalterate le sue caratteristiche nel tempo e costituisce un altro passo verso quella ricerca della perfezione che caratterizza tutti i prodotti dell'azienda.

Together with Flumood, the innovative material composed mostly of aluminum hydroxide and synthetic resins a result of the antioniolupi research, the company proposes after two years of experimentation, Quarzomood. The great resistance, due to the addition of quartz, allows for new colors. The company has developed three different colors, Serena, Terra and Seta, which allow refined combinations of integrated surfaces and sinks, both with the new furniture finishes and with the lacquered and uniform versions.

Extremely resistant, easy to clean, easily restored in case of scratches, burns or wear and tear of everyday use, Quarzomood maintains its characteristics unchanged over time and represents another step towards the search for perfection that characterizes all the company's products.





Top in Quarzomood Serena

Top in Quarzomood Serena

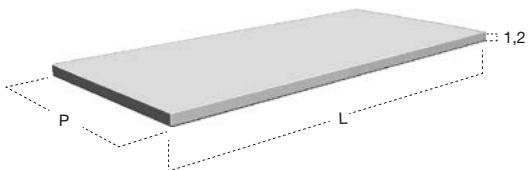
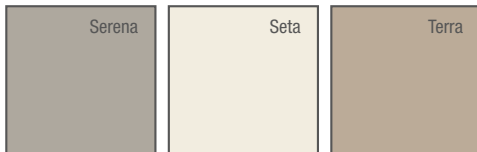

Per collezione / For collection

ORMA - ATELIER - BESPOKE - PIANA - LUNARIA

H	P	L	art.
1,2	40	da / from 72 a / to 218,4	QM140
	47		QM147
	54		QM154

Per collezione / For collection

PANTA REI

H	P	L	art.
1,2	40	da / from 72 a / to 216	QM240
	47		QM247
	54		QM254

Per collezione / For collection

PLANETA

H	P	L	art.
1,2	40	da / from 72 a / to 216	QM340
	47		QM347
	54		QM354

Top in Quarzomood, spessore 12 mm.

Top in Quarzomood, 12 mm thick.



Top in Quarzomood Seta

Top in Quarzomood Seta

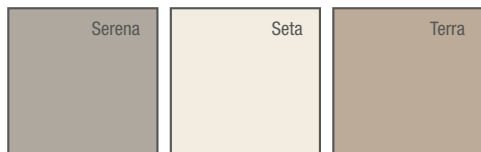

OPTIONAL NIDOQ
Pianetto copripiletta
Cover plate

Art. PIANETTOQ1

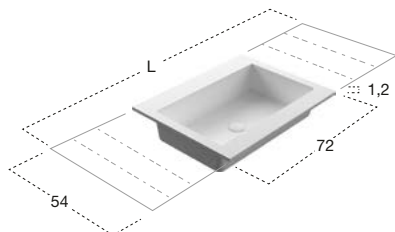
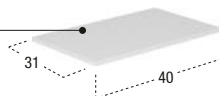

Per collezione / For collection

ORMA - ATELIER - BESPOKE - PIANA - LUNARIA

art.

H	P	L
1,2	54	da / from 72 a / to 218,4

NIDOQ172

Per collezione / For collection

PANTA REI

art.

H	P	L
1,2	54	da / from 72 a / to 216

NIDOQ272

Per collezione / For collection

PLANETA

art.

H	P	L
1,2	54	da / from 72 a / to 216

NIDOQ372

Top con lavabo integrato in Quarzomood completo di piletta con scarico libero e raccordo per sifone, disponibile in diversi colori come da nostro campionario
N.B. solo per porta lavabi H 37,5 e H 50 cm. Nei porta lavabi H 37,5 è possibile inserire solo sifone art. MICRO.

*Top with integrated sink in Quarzomood complete with drain pipe fitting and plug, in various colours as per our samples
P.S. only for sink units cm 37,5 and 50 H. In sink units cm 37,5 H it is only possible to use siphon art. MICRO.*



Top in Quarzomood Terra

Top in Quarzomood Terra

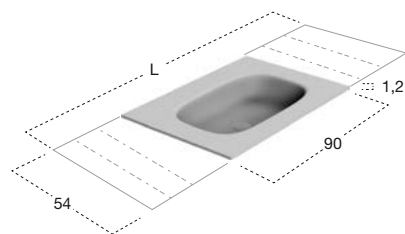
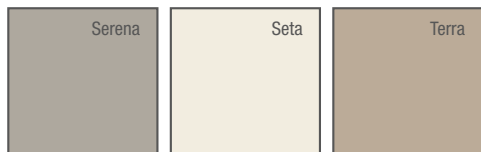

Per collezione / For collection

ORMA - ATELIER - BESPOKE - PIANA - LUNARIA

H	P	L	art.
1,2	54	da / from 90 a / to 218,4	NUVQ190

Per collezione / For collection

PANTA REI

H	P	L	art.
1,2	54	da / from 90 a / to 216	NUVQ290

Per collezione / For collection

PLANETA

H	P	L	art.
1,2	54	da / from 90 a / to 216	NUVQ390

Top con lavabo integrato in Quarzomood completo di piletta con scarico libero e raccordo per sifone, disponibile in diversi colori come da nostro campionario
 N.B. solo per porta lavabi H 37,5 e H 50 cm. Nei porta lavabi H 37,5 è possibile inserire solo sifone art. MICRO.

*Top with integrated sink in Quarzomood complete with drain pipe fitting and plug, in various colours as per our samples
 P.S. only for sink units cm 37,5 and 50 H. In sink units cm 37,5 H it is only possible to use siphon art. MICRO.*



Top in Quarzomood Terra

Top in Quarzomood Terra

BRECCIA design Mario Ferrarini

Un segno forte ma delicato allo stesso tempo, un solco leggero ma evidente sulla superficie che ne connota l'identità, un dettaglio estetico che soddisfa una fondamentale esigenza funzionale, un'idea che risolve un aspetto tecnico e diventa tratto distintivo del progetto. Breccia è un lavabo tondo integrato al top in Flumood realizzabile su misura. La sua particolarità sta proprio nella risoluzione del tema dello scarico, da sempre oggetto di indagine e di ricerca da parte di antoniolupi. Prima azienda a eliminare la piletta tradizionale proponendo soluzioni eleganti e integrate nel design dell'elemento, oggi ha pensato per Breccia a un taglio che permette di defluire l'acqua, un segno che parte da un foro e proprio nel solco che scava nella materia ha il suo continuum che lo collega al perimetro del lavabo.

A strong but delicate mark at the same time, a light but evident groove on the surface that characterizes its identity, an aesthetic detail that satisfies a fundamental functional need, an idea that solves a technical aspect and becomes a distinctive feature of the project. Breccia is a top with a round integrated washbasin in Flumood that can be made to measure. Its particularity lies in how the drain has been developed, a constant subject of investigation and research by antoniolupi. First company to eliminate the traditional waste fitting by proposing elegant and integrated solutions in the design of the element, today it has thought of Breccia, a cut that allows water to flow, a sign that starts from a hole and in the groove digs into the material a continuum that connects it to the perimeter of the sink.





Per collezione / For collection

ORMA - ATELIER - BESPOKE - PIANA - LUNARIA

art.

H	P	L			art.
1,2	54	da / from 72	a / to 272,4		BC154 + BRECCIA
		54	da / from 144	a / to 272,4	BC154 + n° 2 BRECCIA

Per collezione / For collection

PANTA REI

art.

H	P	L			art.
1,2	54	da / from 72	a / to 216		BC254 + BRECCIA
		54	da / from 144	a / to 216	BC254 + n° 2 BRECCIA

Per collezione / For collection

PLANETA

art.

H	P	L			art.
1,2	54	da / from 72	a / to 216		BC354 + BRECCIA
		54	da / from 144	a / to 216	BC354 + n° 2 BRECCIA

Top con singolo o doppio lavabo integrato in Flumood spessore 12 mm finitura Satin, completo di raccordo per sifone.

N.B. solo per porta lavabi H 37,5 e H 50 cm. Nei porta lavabi H 37,5 è possibile inserire solo sifone art. MICRO.

Top with single or double integrated sink in Flumood Satin finish 12 mm thick, with open plug.
N.B. only for sink units cm 37,5 and 50 H. In sink units cm 37,5 H it is only possible to use siphon art. MICRO.

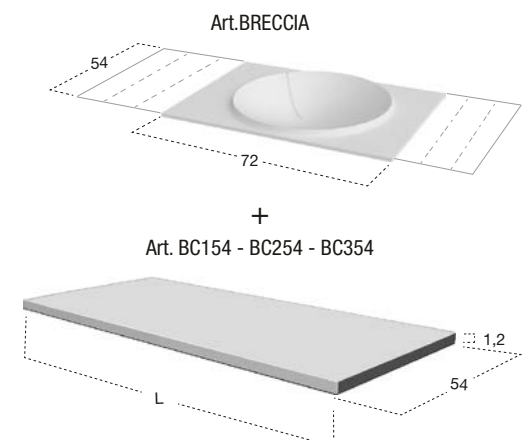





Per collezione / For collection

ORMA - BESPOKE - PIANA - LUNARIA - TEMPRA

art.

H	P	L		
1,2	47	da / from 72	a / to 272,4	BC147 + NUVOLA
	47	da / from 144	a / to 272,4	BC147 + n° 2 NUVOLA

Per collezione / For collection

PANTA REI

art.

H	P	L		
1,2	47	da / from 72	a / to 216	BC247 + NUVOLA
	47	da / from 144	a / to 216	BC247 + n° 2 NUVOLA

Per collezione / For collection

PLANETA

art.

H	P	L		
1,2	47	da / from 72	a / to 216	BC347 + NUVOLA
	47	da / from 144	a / to 216	BC347 + n° 2 NUVOLA

Top con singolo o doppio lavabo integrato in Flumood spessore 12 mm finitura Satin, completo di piletta con scarico libero e raccordo per sifone.

N.B. solo per porta lavabi H 37,5 e H 50 cm. Nei porta lavabi H 37,5 è possibile inserire solo sifone art. MICRO.

Top with single or double integrated sink in Flumood Satin finish 12 mm thick, with drain pipe fitting and open plug.

P.S. only for sink units cm 37,5 and 50 H. In sink units cm 37,5 H it is only possible to use siphon art. MICRO.

Art. NUVOLA

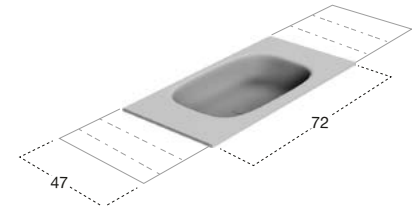

+

Art. BC147 - BC247 - BC347

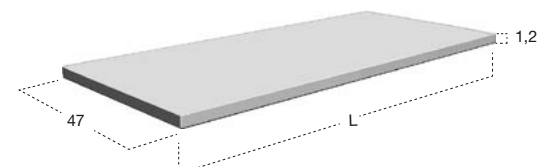





					Per collezione / For collection	
					ORMA - ATELIER - BESPOKE - PIANA - LUNARIA	
H	P	L			art.	
1,2	47	da / from 54	a / to 272,4	BC147 + NIDO54		
	47	da / from 108	a / to 272,4	BC147 + n° 2 NIDO54		
					Per collezione / For collection	
					PANTA REI	
H	P	L			art.	
1,2	47	da / from 54	a / to 216	BC247 + NIDO54		
	47	da / from 108	a / to 216	BC247 + n° 2 NIDO54		
					Per collezione / For collection	
					PLANETA	
H	P	L			art.	
1,2	47	da / from 54	a / to 216	BC347 + NIDO54		
	47	da / from 108	a / to 216	BC347 + n° 2 NIDO54		

Top con singolo o doppio lavabo integrato in Flumood spessore 12 mm finitura Satin, completo di piletta con scarico libero e raccordo per sifone.
 N.B. solo per porta lavabi H 37,5 e H 50 cm. Nei porta lavabi H 37,5 è possibile inserire solo sifone art. MICRO.

*Top with single or double integrated sink in Flumood Satin finish 12 mm thick, with drain pipe fitting and open plug.
 P.S. only for sink units cm 37,5 and 50 H. In sink units cm 37,5 H it is only possible to use siphon art. MICRO.*

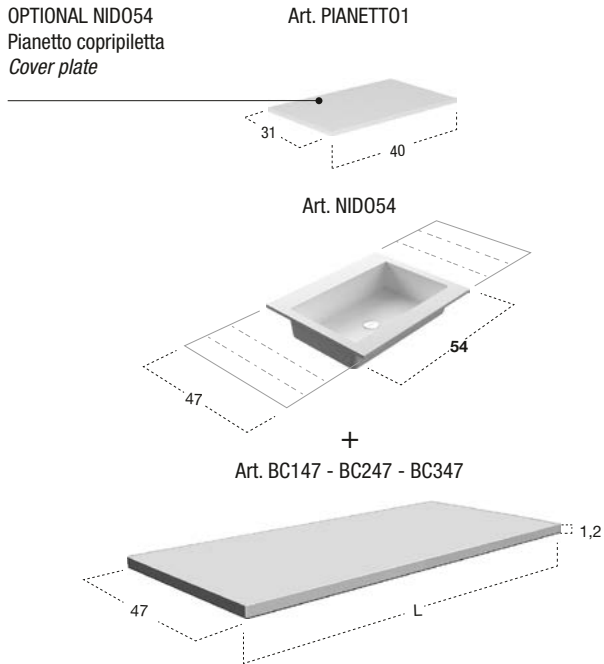



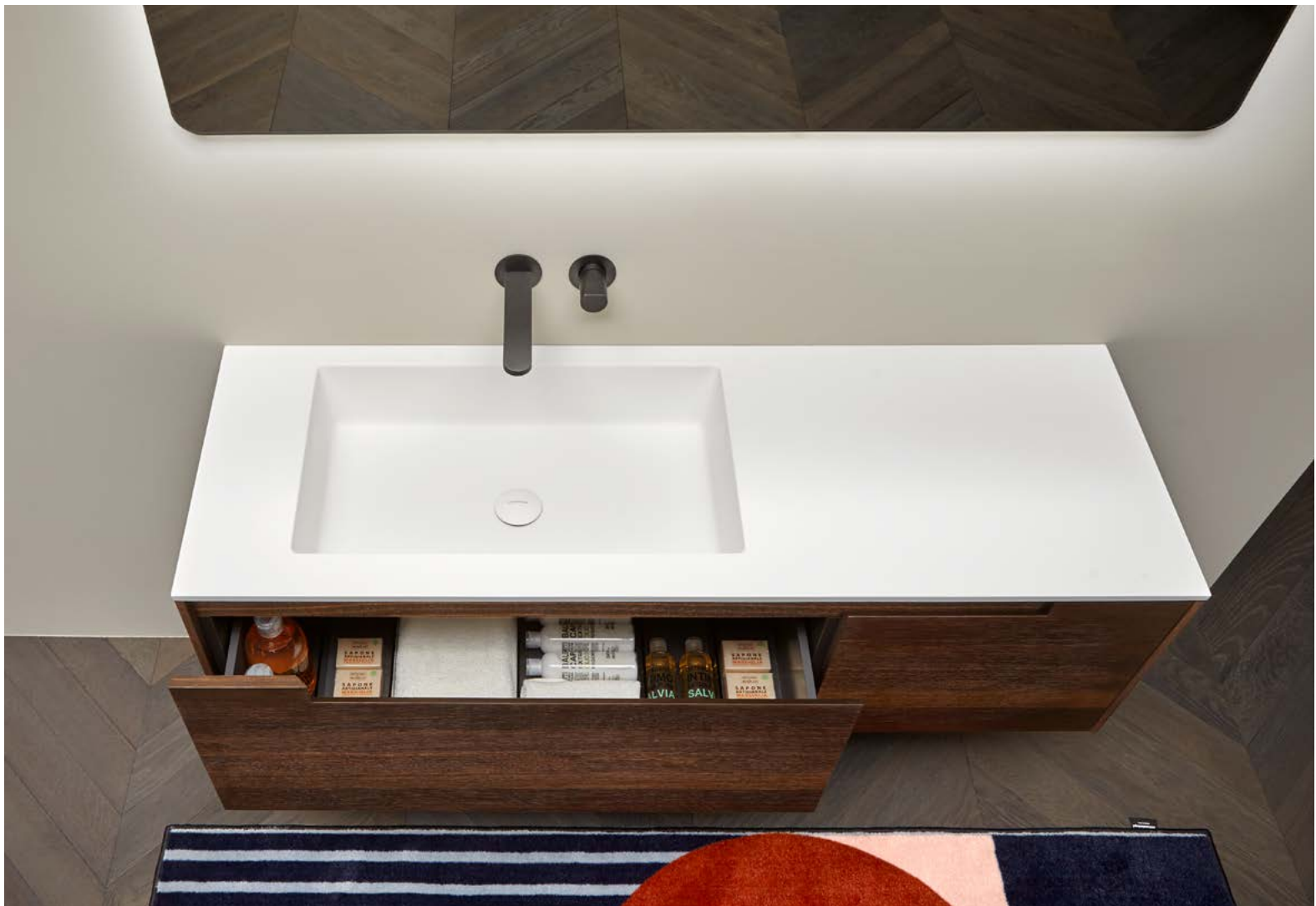

Per collezione / For collection				
H	P	L		art.
1,2	47	da / from 72	a / to 272,4	BC147 + NID072
	47	da / from 144	a / to 272,4	BC147 + n° 2 NID072
Per collezione / For collection				
PANTA REI				
H	P	L		art.
1,2	47	da / from 72	a / to 216	BC247 + NID072
	47	da / from 144	a / to 216	BC247 + n° 2 NID072
Per collezione / For collection				
PLANETA				
H	P	L		art.
1,2	47	da / from 72	a / to 216	BC347 + NID072
	47	da / from 144	a / to 216	BC347 + n° 2 NID072

Top con singolo o doppio lavabo integrato in Flumood spessore 12 mm finitura Satin, completo di piletta con scarico libero e raccordo per sifone.
 N.B. solo per porta lavabi H 37,5 e H 50 cm. Nei porta lavabi H 37,5 è possibile inserire solo sifone art. MICRO.

*Top with single or double integrated sink in Flumood Satin finish 12 mm thick, with drain pipe fitting and open plug.
 P.S. only for sink units cm 37,5 and 50 H. In sink units cm 37,5 H it is only possible to use siphon art. MICRO.*

OPTIONAL NID072
 Pianetto copripiletta
 Cover plate

Art. PIANETTO2

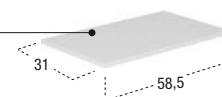

Art. NID072

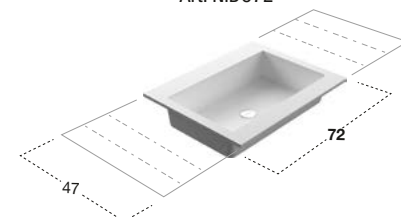

+
 Art. BC147 - BC247 - BC347

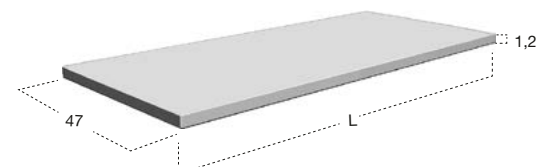





Per collezione / For collection					ORMA - ATELIER - BESPOKE - PIANA - LUNARIA	
H	P	L	art.			
1,2	54	da / from 54	a / to 272,4	BC154 + NID054		
		54	a / to 272,4	BC154 + n° 2 NID054		

Per collezione / For collection					PANTA REI	
H	P	L	art.			
1,2	54	da / from 54	a / to 216	BC254 + NID054		
		54	a / to 216	BC254 + n° 2 NID054		

Per collezione / For collection					PLANETA	
H	P	L	art.			
1,2	54	da / from 54	a / to 216	BC354 + NID054		
		54	a / to 216	BC354 + n° 2 NID054		

Top con singolo o doppio lavabo integrato in Flumood spessore 12 mm finitura Satin, completo di piletta con scarico libero e raccordo per sifone.
 N.B. solo per porta lavabi H 37,5 e H 50 cm. Nei porta lavabi H 37,5 è possibile inserire solo sifone art. MICRO.

*Top with single or double integrated sink in Flumood Satin finish 12 mm thick, with drain pipe fitting and open plug.
 P.S. only for sink units cm 37,5 and 50 H. In sink units cm 37,5 H it is only possible to use siphon art. MICRO.*

OPTIONAL
Troppopieno
Overflow



OPTIONAL NID054
Pianetto copripiletta
Cover plate

Art. PIANETTO1

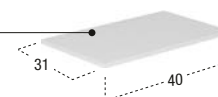

Art. NID054

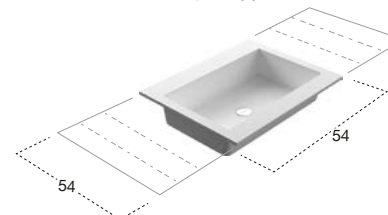

+
Art. BC154 - BC254 - BC354

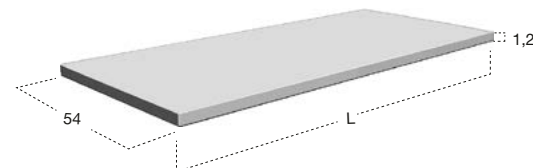





OPTIONAL
Troppopieno
Overflow



Per collezione / For collection

ORMA - ATELIER - BESPOKE - PIANA - LUNARIA

art.

H	P	L			
1,2	54	da / from 72	a / to 272,4	BC154 + NID072	
	54	da / from 144	a / to 272,4	BC154 + n° 2 NID072	

Per collezione / For collection

PANTA REI

art.

H	P	L			
1,2	54	da / from 72	a / to 216	BC254 + NID072	
	54	da / from 144	a / to 216	BC254 + n° 2 NID072	

Per collezione / For collection

PLANETA

art.

H	P	L			
1,2	54	da / from 72	a / to 216	BC354 + NID072	
	54	da / from 144	a / to 216	BC354 + n° 2 NID072	

Top con singolo o doppio lavabo integrato in Flumood spessore 12 mm finitura Satin, completo di piletta con scarico libero e raccordo per sifone.

N.B. solo per porta lavabi H 37,5 e H 50 cm. Nei porta lavabi H 37,5 è possibile inserire solo sifone art. MICRO.

Top with single or double integrated sink in Flumood Satin finish 12 mm thick, with drain pipe fitting and open plug.

P.S. only for sink units cm 37,5 and 50 H. In sink units cm 37,5 H it is only possible to use siphon art. MICRO.

OPTIONAL NID072
Pianetto copripiletta
Cover plate

Art. PIANETTO2

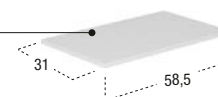

Art. NID072

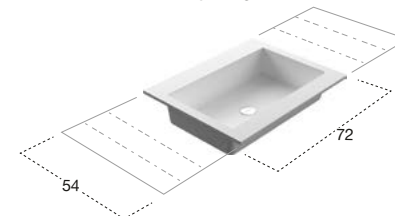

+
Art. BC154 - BC254 - BC354

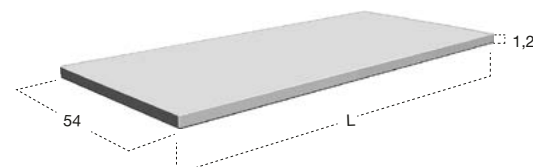

BLOOM design Daniel Debiassi e Federico Sandri

Sottile come un foglio di carta, accogliente e profondo ma allo stesso tempo leggero e delicato. Bloom è il lavabo da appoggio dalla forma inedita che nasce da una geometria rigorosa ma si addolcisce enfatizzando la sottigliezza della materia e lo spessore del bordo che sembra annullarsi. Le linee morbide che si aprono salendo verso l'alto invitano all'utilizzo del lavabo e accompagnano i gesti, facilitando l'esperienza, mentre la base rimane importante e ben ancorata al piano. I 4 tagli negli angoli rimandano all'immagine di una scatola che si apre e diventano il segno distintivo della collezione. Dettagli semplici che si trasformano in decoro contemporaneo e contribuiscono alla trasposizione di significato del materiale. Il foglio sembra infatti strapparsi sottoposto alla forza dell'acqua ma in realtà l'involucro è resistente, solido e assicura una grande capacità al bacino.

Thin like a sheet of paper, cozy and deep but at the same time light and delicate. Bloom is the top mount basin with an original shape that comes from a rigorous geometry but softens emphasizing the subtlety of the material and the thickness of the border that seems to cancel out. The soft lines that open upwards invite the use of the sink and accompany the gestures, facilitating the experience, while the base remains important and well anchored to the top. The 4 cuts in the corners refer to the image of a box that opens and becomes the hallmark of the collection. Simple details that are transformed into contemporary decor and contribute to the transposition of the material's meaning. In fact, the sheet seems to tear off because subjected to the force of the water but in reality the casing is resistant, solid and ensures a great capacity to the basin.







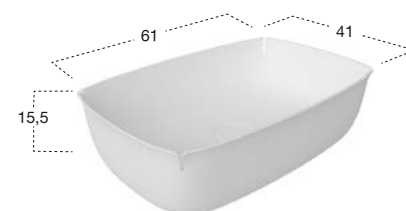
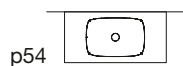
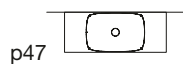
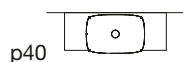

H	P	L	art.
15,5	41	61	BLOOM

Lavabo rettangolare sopra piano in Flumood completo di piletta con scarico libero e raccordo per sifone.

Rectangular top mount Flumood sink complete with drain pipe fitting and open plug.

RIM design Daniel Debiasi e Federico Sandri

Tondo o ovale, Rim è il nuovo lavabo ultrasottile che ha nella morbidezza e nella continuità del bordo il proprio tratto distintivo. Come una foglia leggera che si adagia su uno specchio d'acqua Rim si appoggia sul piano con delicatezza, quasi a sfiorare la superficie. La profondità ridotta del bacino e la sezione continua che si completa con un bordo arrotondato conferiscono contemporaneità all'insieme. Il volume sottile del lavabo riporta idealmente alla bidimensionalità della geometria generatrice, sottolineata dallo specchio d'acqua che si verrà a creare al suo interno.

Round or oval, Rim is the new ultra-thin sink that has its own distinctive feature in the softness and continuity of the border. Like a light leaf that lies on a mirror of water, Rim rests gently on the surface, almost touching the surface. The reduced depth of the bowl and the continuous section which is completed with a rounded edge give the whole a contemporary appearance. The subtle volume of the sink ideally returns to the two-dimensionality of the generating geometry, underlined by the mirror of water that will be created inside.







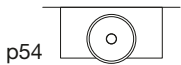
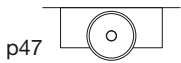

H	Ø	art.
13,6	54	RIM54

Lavabo tondo sopra piano in Flumood, completo di piletta con scarico libero e raccordo per sifone.

Round top mount Flumood sink, complete with drain pipe fitting and open plug.

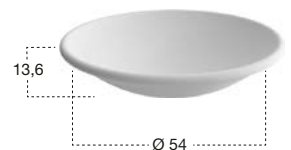



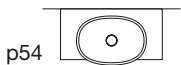
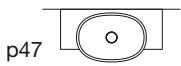

H	P	L	art.
13,6	54	76	RIM76

Lavabo ovale sopra piano in Flumood completo di piletta con scarico libero e raccordo per sifone.

Oval top mount Flumood sink complete with drain pipe fitting and open plug.



VELO design Mario Ferrarini

Versatile, trasversale, perfetta per inserirsi in contesti diversi di stile. La collezione di lavabi Velo, disponibile nelle forme tonda, ovale e rettangolare, si aggiorna per incontrare il gusto contemporaneo. Nel rispetto del concept originale, delle geometrie e delle dimensioni della serie, i bordi si fanno però più sottili di 5 mm conferendo maggiore leggerezza all'insieme e allo stesso tempo garantendo un maggior volume del bacino. Rimane invariata la caratteristica forma delle versioni tonda e ovale con la base d'appoggio molto stretta e il bacino molto più ampio, mentre nella versione rettangolare con spigoli arrotondati il volume è perfettamente ortogonale.

Versatile, transversal, perfect to fit in different environments. The Velo washbasin collection, available in round, oval and rectangular shapes, is updated to meet a contemporary inclination. Considering the original concept, geometry and dimensions of the series, the edges are 5 mm giving greater lightness to the whole and at the same time ensuring a greater volume of the basin. The typical round and oval shapes remain unmodified with a very narrow base for support and a wider bowl, while the rectangular version with rounded corners has a perfectly perpendicular volume.





VELO





antonolupi



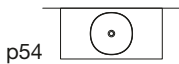
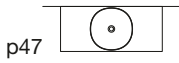
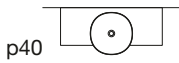

Verniciabile esternamente in tutti i colori del nostro campionario
Can be externally lacquered in all colors of our collection

H	P	L	art.
15	45	45	VELOTONDO45

Lavabo tondo sopraiano in Flumood, completo di piletta con scarico libero e raccordo per sifone.

Round top mount Flumood sink, complete with drain pipe fitting and open plug.

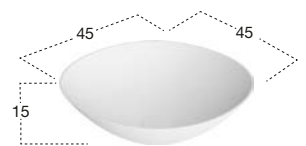



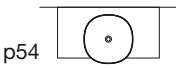

Verniciabile esternamente in tutti i colori del nostro campionario
Can be externally lacquered in all colors of our collection

H	Ø	art.
13	54	VELOTOND054

Lavabo tondo sopra piano in Flumood, completo di piletta con scarico libero e raccordo per sifone.

Oval top mount Flumood sink, complete with drain pipe fitting and open plug.

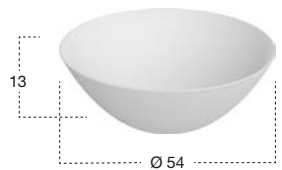





VEL054

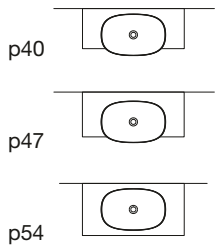

VEL063

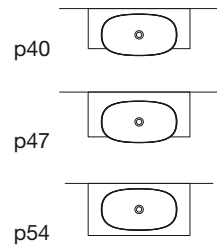

Verniciabile esternamente in tutti i colori del nostro campionario
Can be externally lacquered in all colors of our collection

H	P	L	art.
15	35	54	VEL054
15	35	63	VEL063

Lavabo ovale sopra-piano in Flumood, completo di piletta con scarico libero e raccordo per sifone.

Oval top mount Flumood sink, complete with drain pipe fitting and open plug.

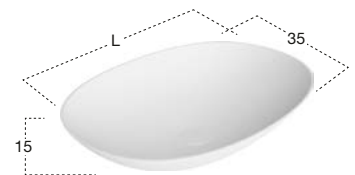

VELO









VELORETT050

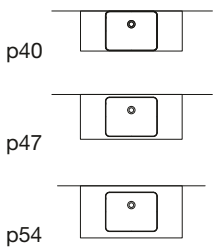

VELORETT063

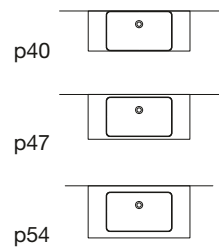

Verniciabile esternamente in tutti i colori del nostro campionario
Can be externally lacquered in all colors of our collection

H	P	L	art.
13	38	50	VELORETT050
13	38	63	VELORETT063

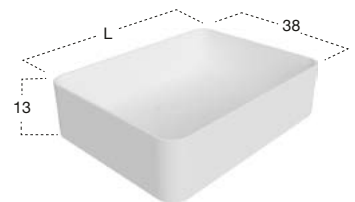

Lavabo rettangolare sopra piano o sottopiano in Flumood, completo di pileta con scarico libero e raccordo per sifone.

Rectangular top mount or undermount Flumood sink, complete with drain pipe fitting and open plug.

AG0185 design Mario Ferrarini

Una nuova versione che esprime tutte le potenzialità del gesto, che valorizza al meglio il design elegante e armonico della collezione. Un'identità forte e allo stesso tempo naturale che trova nell'impiego del nuovo materiale un prezioso alleato per la lettura complessiva del progetto. È la sintesi armonica di volumi essenziali, è l'incontro virtuoso tra la geometria perfetta del bacino circolare dai bordi sottili e la base cilindrica che si restringe verso l'alto. Proprio la delicatezza con cui è risolto il raccordo tra base e bacino è il tratto essenziale della collezione e in particolare di questo lavabo freestanding che diventa il fulcro di un ambiente bagno contemporaneo e trasversale.

A new version that expresses the potential of the gesture which enhances the best elegant and harmonious design of the collection. A strong yet natural identity that when using the new material is a valuable ally for the overall interpretation of the project. Is the harmonious synthesis of essential volumes, is the virtuous encounter between the perfect geometry of the circular basin with thin edges and the cylindrical base that narrows upwards. Just the delicacy with which it solves the connection between the base and the basin is the essential feature of the collection, and in particular of this freestanding washbasin that becomes the focus of a contemporary and transversal bathroom.







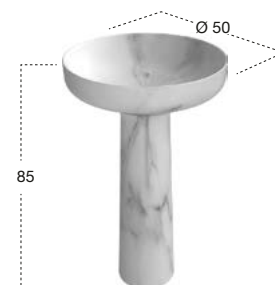

	H	Ø	art.
Marmo Carrara / Nero Marquina	85	50	AG0185

Lavabo da terra in pietra con scarico a pavimento, completo di piletta con scarico libero, sifone e tubo flessibile.

Peso lavabo: 57 kg ca.

*Freestanding stone sink with floor drainage complete with open plug, siphon and flexible hose.
Sink weight: 57 kg approx.*



INTRECCIO design Paolo Ulian

Un cesto di vimini, un fiore dalla corolla ad anelli, una stella filante che grazie a un soffio leggero rivela una magia inaspettata. Il lavoro dell'uomo incontra la natura per dar vita a Intreccio, il lavabo freestanding interamente realizzato in marmo, che gioca sul rapporto tra leggerezza del segno e la solidità del materiale utilizzato, sull'equilibrio tra un artificio sofisticato e una forma apparentemente naturale. Intreccio rappresenta la naturale evoluzione del percorso intrapreso più di un anno fa da antoniolupi e Paolo Ulian per indagare il rapporto tra un materiale antico e nuove tecniche di lavorazione.

Iconico come i precedenti lavabi della collezione, dinamico, per la particolare geometria dei layer concentrici che vengono sfalsati quando vengono sovrapposti procedendo verso l'alto così da determinare un gioco di chiaroscuri e pieni e vuoti ottenuto unicamente dalla variazione della luce sulle forme concave o convesse. Intreccio nasce infatti da un blocco di marmo sul quale sono stati ottimizzati i tagli per ricavare tutte le parti necessarie a dar vita a un volume tridimensionale. Le tecnologie di lavorazione a controllo numerico hanno permesso di ottenere forme curvilinee e sottili, leggere quasi come se fossero di un altro materiale e non di marmo. Con Intreccio la ricerca di antoniolupi indaga un tema tanto caro all'azienda che è quello del risparmio delle risorse e dei materiali. Un unico blocco di marmo viene tagliato in 4 dai quali vengono ricavati 4 lavabi. Gli anelli che compongono Intreccio sono concentrici perché devono essere ricavati uno dentro l'altro dal blocco di marmo riducendo drasticamente gli scarti prodotti dal taglio. Senza dimenticare la leggerezza perché da sempre il peso è un fattore rilevante nella realizzazione di manufatti in marmo. Intreccio pesa "solo" 55 kg.

Leggerezza, tecnologia che diventa espressione estetica e risparmio di materiale sintetizzano al meglio un progetto di grande impatto, un elemento attorno al quale dar vita a una composizione dell'ambiente bagno elegante e contemporanea.

A wicker basket, a flower with a ringed corolla, a streamlined star that, thanks to a light breath, reveals an unexpected magic. The work of man meets nature to give life to Intreccio, the freestanding washbasin entirely made of marble, which plays on the relationship between lightness and solidity of the material used, on the balance between a sophisticated piece and an apparently natural form. Intreccio represents the natural evolution of the path undertaken more than a year ago by antoniolupi and Paolo Ulian, to investigate the relationship between an ancient material and new processing techniques.

Iconic like the previous washbasins of the collection, dynamic, for the particular geometry of the concentric layers that are staggered when they are overlapped proceeding upwards, so as to determine a play of light and dark and full and empty obtained only by the variation of light on concave or convex shapes. In fact, Intreccio is born from a block of marble on which the cuts have been optimized to obtain all the parts necessary to create a three-dimensional volume. The numerical control machining technologies have allowed to obtain curvilinear and thin shapes, light, almost as if they were of another material and not of marble. With Intreccio, the research of antoniolupi further investigates a topic that is of saving resources and materials. A single block of marble is divided into 4 from which 4 washbasins are made. The rings that make up Intreccio are concentric because they have to be obtained one inside the other from the block of marble drastically reducing the waste produced by the cut. Without forgetting lightness because weight has always been a significant factor in the production of marble products. Intreccio weighs "only" 55 kg.

Lightness, technology that becomes an aesthetic expression and material savings summarize at best a project of great impact, an element which gives life to a composition of the elegant and contemporary bathroom.

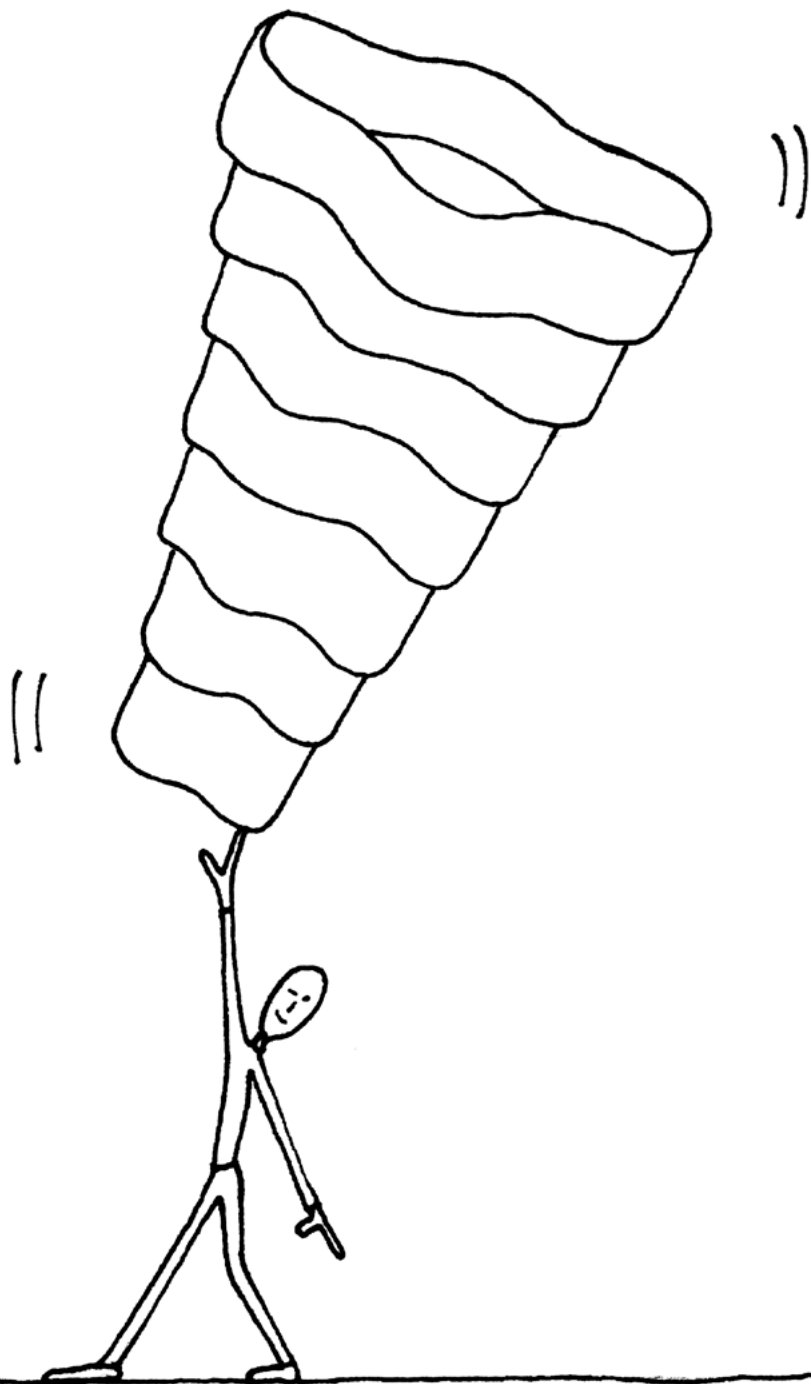

INTRECCIO

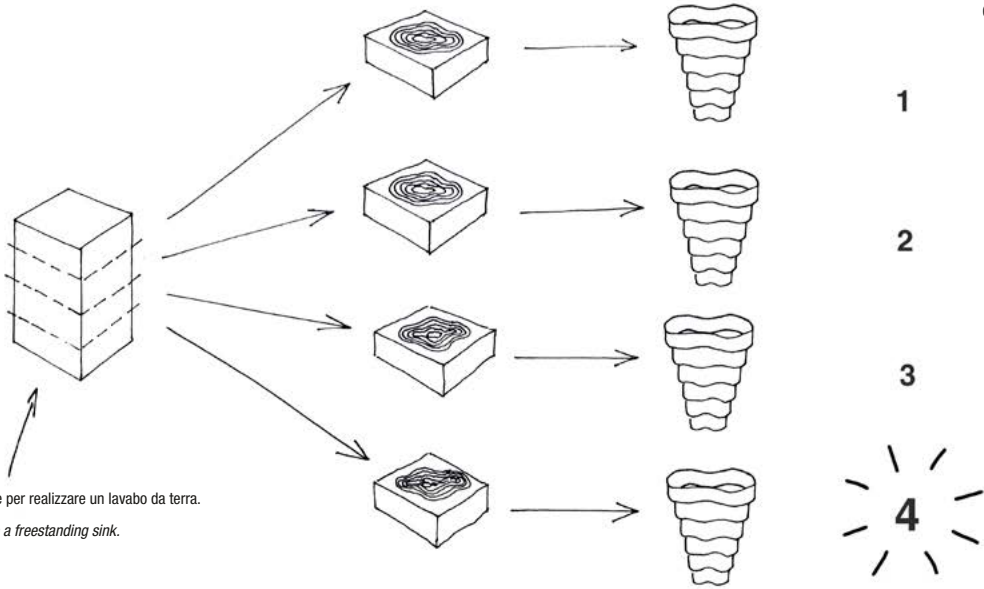
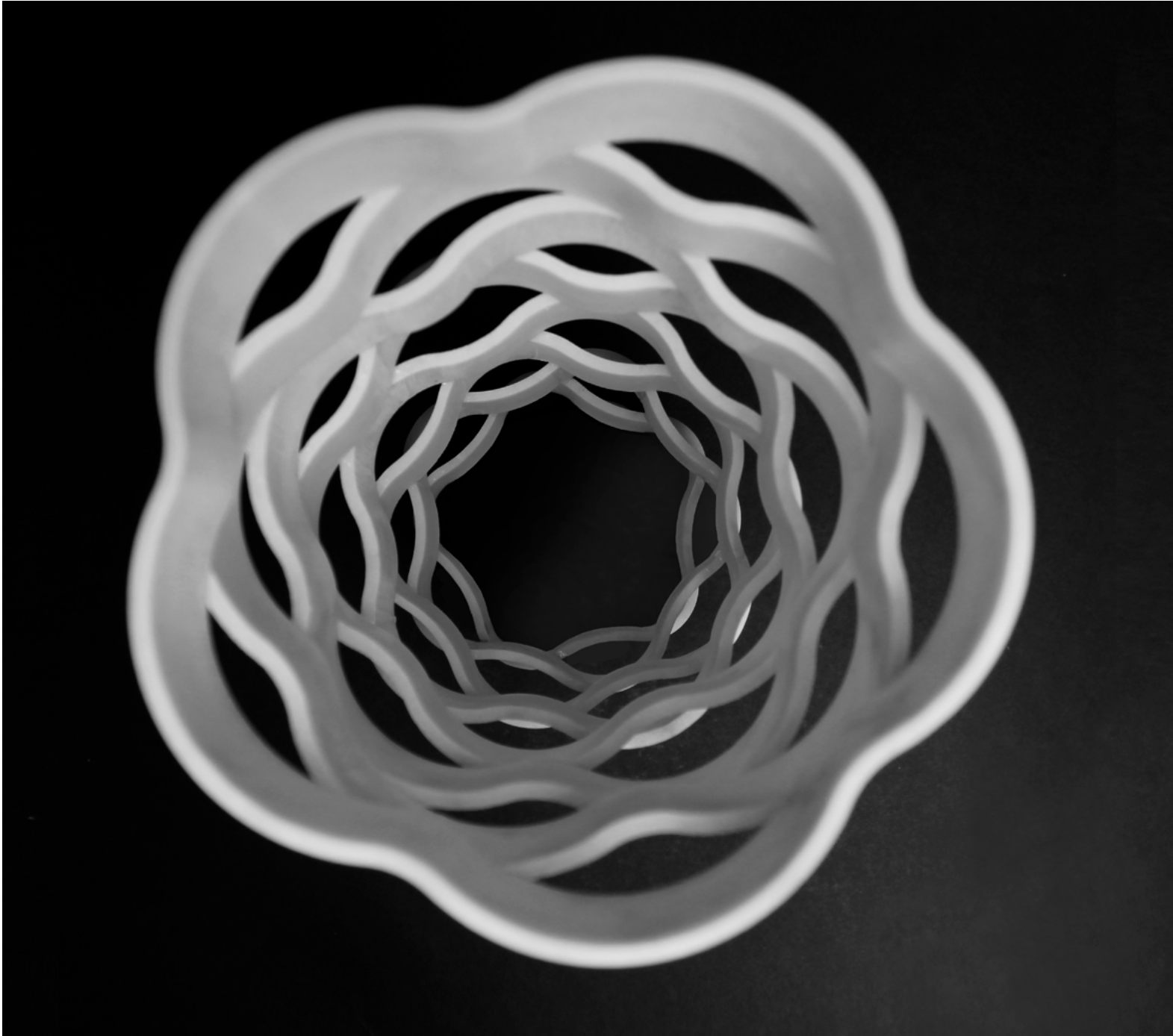

Blocco di marmo usato solitamente per realizzare un lavabo da terra.
 Marble block usually used to make a freestanding sink.

Con lo stesso blocco di marmo si ottengono 4 lavabi "Intreccio".
 With the same block of marble 4 "Intreccio" sinks are obtained.

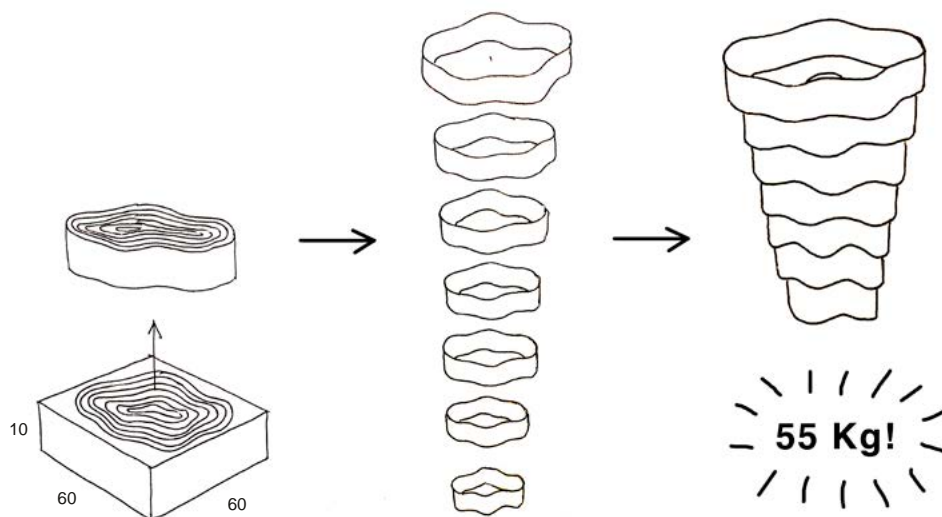



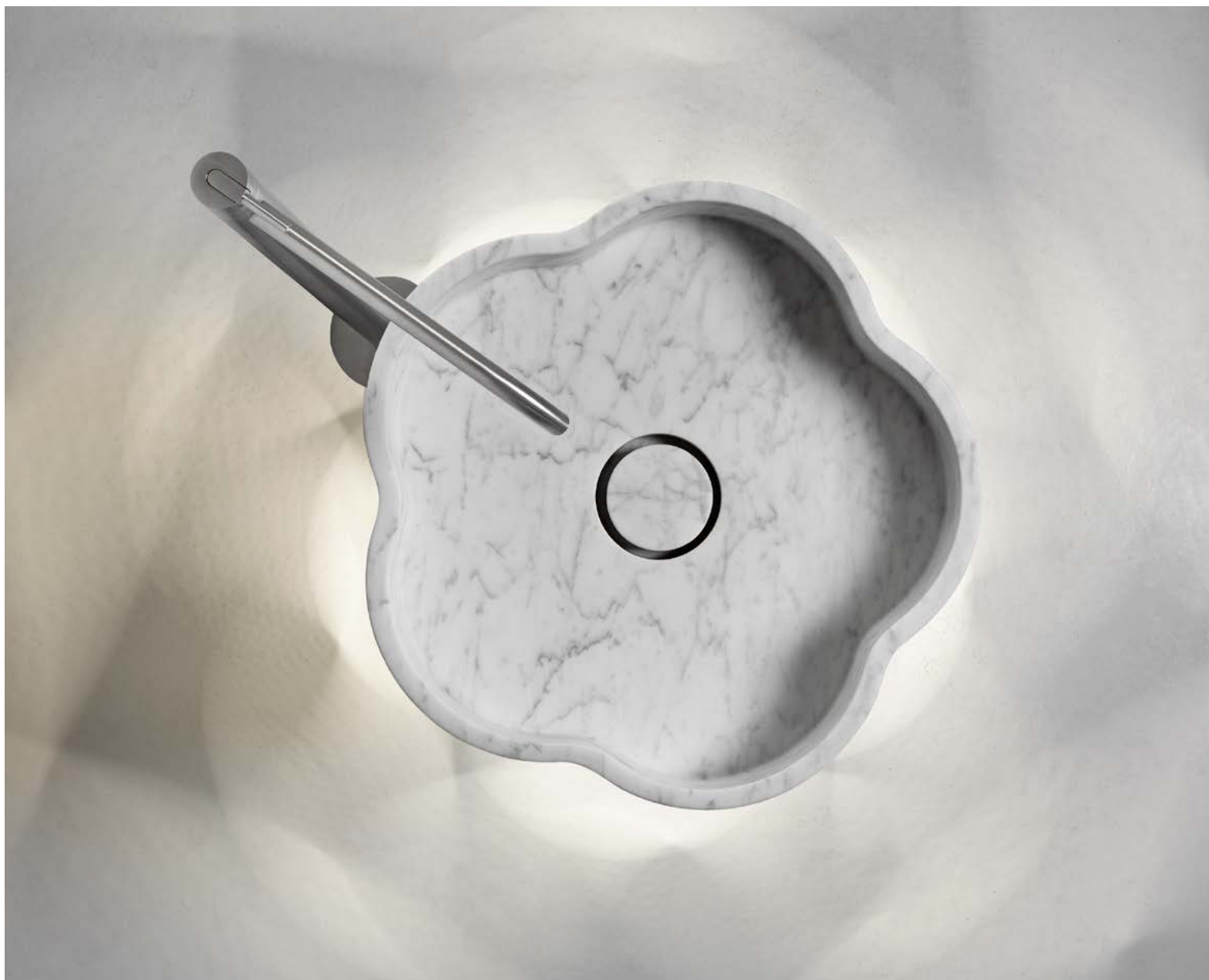

	H	Ø	art.
Marmo Carrara	85	47,5	INTRECCIO
Marmo Carrara LED	85	47,5	INTRECCIOL

Lavabo da terra in pietra con scarico a pavimento, con o senza illuminazione a led, completo di piletta con scarico libero, sifone e tubo flessibile.

Peso lavabo: 55 kg ca.

Freestanding stone sink with floor drainage with or without led lighting, complete with open plug, siphon and flexible hose.

Sink weight: 55 kg approx

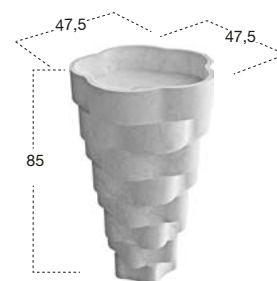



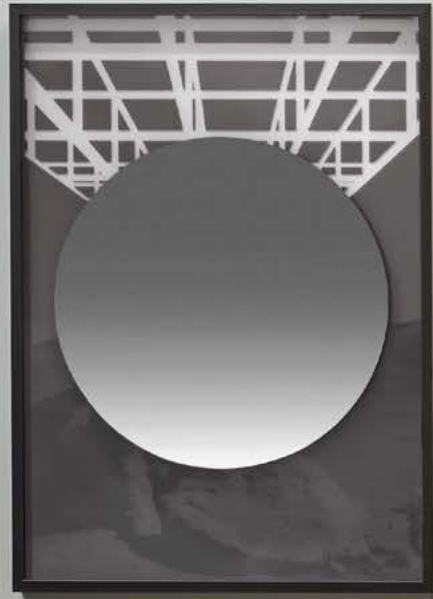

INTROVERSO design Paolo Ulian

Modello e design registrato, brevetto depositato
Registered model and design, patent filed









	H	Ø	art.
Marmo Carrara	85	45	INTROVERSO1

Lavabo da terra in pietra con scarico a pavimento, completo di piletta con scarico libero, sifone e tubo flessibile. Peso lavabo: 223 kg ca.

*Freestanding stone sink with floor drainage complete with open plug, siphon and flexible hose.
Sink weight: 223 kg approx*

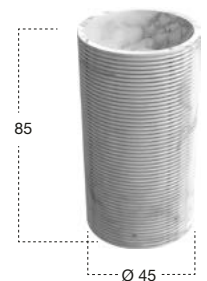

INTROVERSO

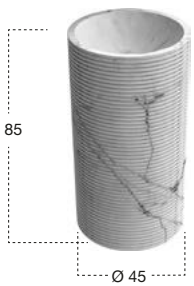

	H	Ø	art.
Marmo Carrara	85	45	INTROVERSO2

Lavabo da terra in pietra con scarico a pavimento, completo di piletta con scarico libero, sifone e tubo flessibile.
Peso lavabo: 223 kg ca.

*Freestanding stone sink with floor drainage complete with open plug, siphon and flexible hose.
Sink weight: 223 kg approx.*



H	Ø	art.	
85	45	INTROVERSO3	Marmo Carrara

Lavabo da terra in pietra con scarico a pavimento, completo di piletta con scarico libero, sifone e tubo flessibile.

Peso lavabo: 223 kg ca.

*Freestanding stone sink with floor drainage complete with open plug, siphon and flexible hose.
Sink weight: 223 kg approx*

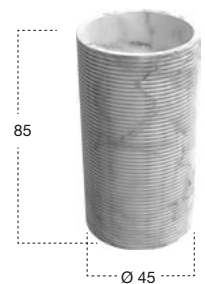



CRISTALMOOD

Una nuova resina dalle straordinarie caratteristiche tecniche, pensata per conferire leggerezza e allo stesso tempo solidità a vasche e lavabi, un materiale che permette di realizzare forme morbide e accoglienti e di restituire all'acqua il ruolo di protagonista. La trasparenza della superficie consente infatti di osservare il flusso del liquido, di leggerne i movimenti, di assecondarne la forza. Dopo il lancio allo scorso Salone del Mobile, antoniolupi ha messo a punto nove nuovi colori di tendenza che vanno ad aggiungersi alla proposta Fumè, grazie ai quali conferire identità all'oggetto integrandolo al meglio nel contesto di stile dell'ambiente bagno. Sono nate così le tonalità Nebbia, Ocra, Bottiglia, Petrolio, Ginger, Cobalto, Sangria, Ambra e Lime che conferiscono colore, eleganza e vivacità ai volumi plastici realizzati in Cristalmoood. Le variazioni cromatiche che assecondano le geometrie e le linee curve di lavabi e vasche donano plasticità agli elementi, in un costante dialogo con la luce.

A new resin with extraordinary technical characteristics, designed to give lightness yet at the same time solidity to bathtubs and washbasins, a material that makes it possible to create soft and welcoming shapes and to restore the role of protagonist to water. The transparency of the surface makes it possible to observe the flow of the liquid, to read its movements, to follow its strength. After the launch at the last Salone del Mobile, antoniolupi has developed nine new trendy colors that are added to the Fumè proposal, thanks to which identity is awarded to the item, integrating it best in the context of bathroom style. Thus Nebbia, Ocra, Bottle, Petroleum, Ginger, Cobalt, Sangria, Amber and Lime shades were born, which give color, elegance and liveliness to the plastic volumes made in Cristalmoood. The chromatic variations that follow the geometry and the curved lines of washbasins and tubs give plastic behavior to the elements in a constant dialogue with the light.





cobalto



sangria



ambra



lime



ginger



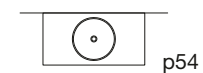
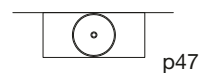

H	Ø	art.
15	43	CATINO43C

Lavabo tondo sopra piano in Cristalmood, disponibile in diversi colori come da nostro campionario completo di piletta con scarico libero e raccordo per sifone.

Round top mount sink in Cristalmood, available in various colors complete with drain pipe fitting and open plug.

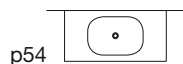
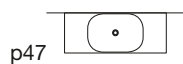
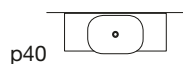

H	P	L	art.
15	40	60	SENSOC

Lavabo rettangolare sopra piano in Cristalmood, disponibile in diversi colori come da nostro campionario, completo di piletta con scarico libero e raccordo per sifone.

Rectangular top mount sink in Cristalmood, available in various colors complete with drain pipe fitting and open plug.



ALBUME design Carlo Colombo

Leggerezza e solidità, rigore ed espressività, materia e colore. La poetica degli opposti, l'equilibrio che nasce dalla sovrapposizione di forme geometriche diverse, l'insieme che si manifesta solo nel rapporto proporzionale perfetto fra le parti. Albume è il lavabo freestanding disegnato da Carlo Colombo che vive dell'alternanza tra un basamento che esprime solidità e resistenza e un bacino trasparente e colorato che lascia all'acqua il ruolo di protagonista. Una nuova resina trasparente permette di realizzare la vasca del lavabo, disponibile in due forme differenti che definiscono un'immagine più slanciata o al contrario più morbida e accogliente. I raffinati contrasti cromatici tra i colori della parte superiore e le infinite declinazioni del marmo utilizzato per il basamento permettono di personalizzare il lavabo e conferire un carattere specifico all'insieme. Proprio in questo senso, Albume si inserisce perfettamente all'interno di ambienti bagno raffinati, nei quali i suoi materiali si armonizzano con le superfici e gli altri elementi della composizione dello spazio. La colonna realizzata in marmo Bianco Carrara o Nero Marquinia conferisce ancora più eleganza e prestigio al progetto per dialogare con rivestimenti, pavimenti o piani di lavoro.

Lightness and solidity, rigor and expressiveness, material and color. Poetry of opposites, the balance that arises from the superposition of geometric shapes, a perfect and proportional relationship between the parts. Albume is the freestanding washbasin designed by Carlo Colombo that alternates between a solid base that expresses strength and a transparent and colored basin that leaves water as the protagonist. A new transparent resin allows to create the basin of the sink, available in two different shapes that define a more slender image or on the contrary softer and welcoming. The refined color contrasts between the upper part and the infinite variations of the marble used for the base allow you to customize the sink and give a specific character to the whole. Precisely in this sense, Albume fits perfectly into refined bathrooms, in which its materials harmonize with the surfaces and other elements of the composition of the space. The base made in Bianco Carrara or Nero Marquinia marble to give more elegance and prestige to a project and to dialogue with walls, floors or work surfaces.



Cristalmood fumé / Marmo Carrara



Cristalmood fumé / Nero Marquinia

ALBUME



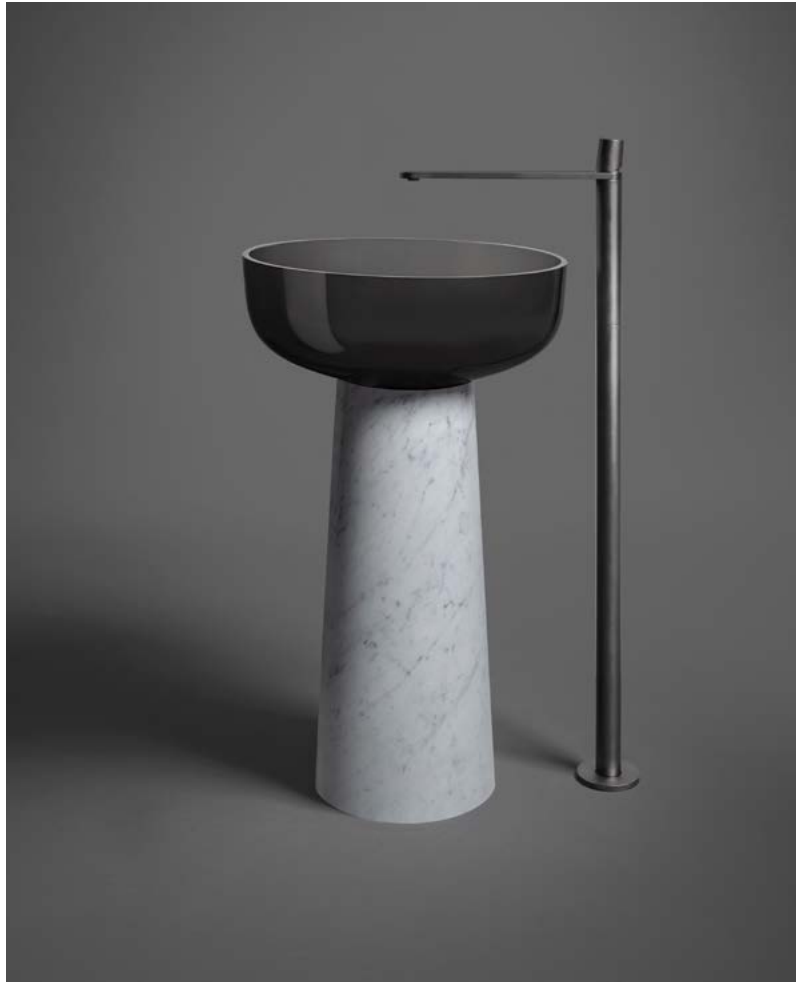

ALBUME



Cristalmood fumé / Cristalmood fumé



Cristalmood fumé / Cristalmood fumé



bottiglia



ambra



cobalto



lime



fumè

ALBUME



nebbia



petrolio



sangria



ocra



ginger



nebbia / cobalto



nebbia / bottiglia



sangria / ginger



ginger / sangria



ocra / petrolio



cobalto / nebbia



petrolio / fumé



ambra / lime



petrolio / ocra



ginger / nebbia



bottiglia / lime



cobalto / petrolio



petrolio / cobalto



bottiglia / sangria



nebbia / ginger



ginger / ambra



lime / bottiglia



sangria / bottiglia



H	Ø	art.
---	---	------

20,5	48	ALBUME10
------	----	----------

Lavabo tondo in Cristalmood, disponibile in diversi colori come da nostro campionario, sopra piano o abbinabile con colonna art. ALBUME20 e art. ALBUME21, completo di piletta con scarico libero e raccordo per sifone.

Round sink in Cristalmood, available in various colors, top mount or to be combined with pedestal Art. ALBUME20 and Art. ALBUME21 complete with drain pipe fitting and open plug.



H	Ø	art.
---	---	------

20,5	48	ALBUME11
------	----	----------

Lavabo tondo in Cristalmood, disponibile in diversi colori come da nostro campionario, sopra piano o abbinabile con colonna art. ALBUME20 e art. ALBUME21, completo di piletta con scarico libero e raccordo per sifone.

Round sink in Cristalmood, available in various colors, top mount or to be combined with pedestal Art. ALBUME20 and Art. ALBUME21 complete with drain pipe fitting and open plug.



H	Ø	art.
---	---	------

Cristalmood / Resina verniciata	65,5	28	ALBUME20
---------------------------------	------	----	----------

Colonna da terra in Cristalmood o in resina verniciata, disponibile in diversi colori come da nostro campionario, con scarico a pavimento, sifone e tubo flessibile.

Pedestal in stone or Cristalmood available in various colors with floor drainage, siphon and flexible hose.

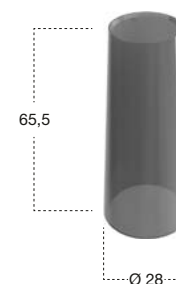

H	Ø	art.
---	---	------

Marmo Carrara / Nero Marquina	65,5	28	ALBUME21
-------------------------------	------	----	----------

Colonna da terra in pietra con scarico a pavimento, sifone e tubo flessibile.

Pedestal in stone with floor drainage, siphon and flexible hose.

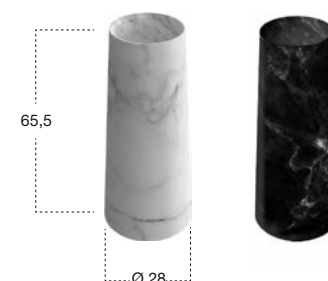

REFLEX design AL Studio

Leggerezza e solidità, rigore ed espressività, materia e colore, la poetica degli opposti. Un nuovo materiale frutto della ricerca antoniolupi, si aggiunge al Flumood e al Quarzomood. Denominato Cristalmoood per le sue caratteristiche di trasparenza e lucentezza, è una resina di nuova generazione, colorabile, resistente, versatile. Cristalmoood è una resina colorata, trasparente, a finitura lucida, composta da resina poliestere di alta qualità e pigmenti coloranti; ha superato i test anticorrosione (nebbia salina) e può essere pulita con tutti i detergenti più comuni, resistendo anche ad alcool denaturato, acetone, olii, benzene o gasolio. Reflex è una vasca dal disegno minimale, con un bordo importante: una vasca che ha l'impatto della pietra, la trasparenza del cristallo e invece, grazie alla sua composizione, un peso inferiore di circa il 30% rispetto ai solid surface come il nostro Flumood.

Lightness and solidity, rigor and expressiveness, material and color, poetry of opposites. A new material, result of the antoniolupi research is added to Flumood and Quarzomood. It is named Cristalmoood due to its transparency and sheen, a new generation colored resin, resistant and versatile. Cristalmoood is a colored resin, transparent with a glossy finish, composed of high quality polyester resin and coloring pigments; has passed the anti-corrosion tests (salt spray) and can be cleaned with all the most common detergents, also resisting to rubbing alcohol, acetone, oils, gasoline or diesel fuel. Reflex has a minimal design and an important border: a bathtub which has the impact of stone and transparency of crystal, instead thanks to its composition, has an inferior weight of almost 30% with respect to solid surfaces such as our Flumood.



petrolio



REFLEX



fumè



ginger

REFLEX





lime



cobalto



sangria



ambra

REFLEX



fumè







fumè

H	P	L	art.
53	86	167	REFLEX

Vasca da bagno ovale in Cristalmood, disponibile nei colori del nostro campionario, completa di piletta con sistema di scarico a pressione klik clak, sifone e tubo flessibile.

Peso vasca: 150 kg
Capacità: 350 l

Oval Cristalmood bathtub available in various colors complete with drain and pressure plug, siphon and flexible hose.

*Weight: 150 kg
Capacity: 350 l*

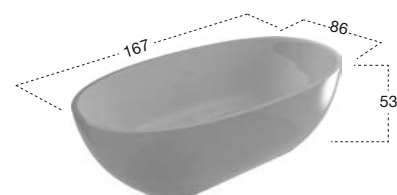





Verniciabile esternamente in tutti i colori del nostro campionario
Can be externally lacquered in all colors of our collection

H	P	L	art.
53	86	167	REFLEXMOOD

Vasca da bagno ovale in Flumood, completa di piletta con sistema di scarico a pressione klik clak, sifone e tubo flessibile.

Peso vasca: 110 kg
 Capacità: 350 l

Oval Flumood bathtub, complete with drain and pressure plug, siphon and flexible hose.

*Weight: 110 kg
 Capacity: 350 l*

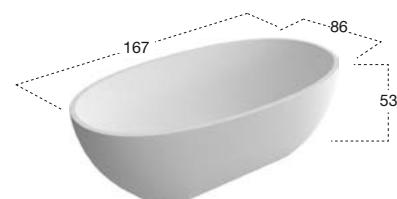

ECLIPSE SMALL design Marco Di Paolo

Realizzata in Cristalplant, elegante e funzionale come la sorella più grande, anche Eclipse Small è una vasca avvolgente dalla forma a uovo che accoglie e protegge ergonomicamente il corpo.

Collocabile facilmente anche in ambienti più piccoli, con la sua lunghezza di 160 cm, non fa rimpiangere vasche che occupano molto più spazio.

Ad accrescerne la funzionalità, Eclipse Small ha una piccola mensola portaoggetti integrata che ne impreziosisce il bordo e che può ospitare quanto serve per avere tutto a portata di mano.

Made of Cristalplant, elegant and functional like its bigger sister, Eclipse Small is also an enveloping egg-shaped bathtub that ergonomically welcomes and protects the body. Can be easily placed even in smaller spaces, with a length of 160 cm, it doesn't make you regret larger bathtubs.

To increase its functionality, Eclipse Small has an integrated shelf that embellishes the edge and that can accommodate everything you need at your fingertips.









Verniciabile esternamente in tutti i colori del nostro campionario
Can be externally lacquered in all colors of our collection

H	P	L	art.
53	75	160	ECLIPSES

Vasca da bagno ovale in Cristalplant, completa di piletta con sistema di scarico a pressione klik clak, sifone e tubo flessibile.

Peso vasca: 82 kg
 Capacità: 240 l

Oval Cristalplant bathtub, complete with drain and pressure plug, siphon and flexible hose.

*Weight: 82 kg
 Capacity: 240 l*

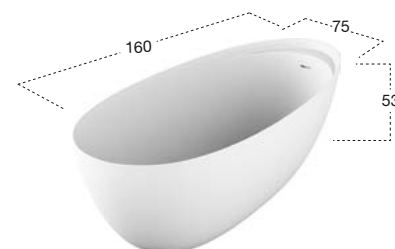

ECLIPSE SMALL













ZENIT10 + ZENITLED



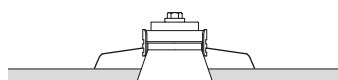

H	Ø	art.
6	8	ZENIT10

Soffione in Delrin nero con struttura ad incasso a soffitto in alluminio nero.

Black Delrin shower with ceiling encasing structure in black aluminum.

FUORIMETEO SLIM design Nevio Tellatin

Modello e design registrato, brevetto depositato
Registered model and design, patent filed

Fuorimeteo viene fornito bianco, la struttura esterna può essere verniciata a piacimento, dello stesso colore della parete o in contrasto.
Fuorimeteo is supplied white, the external structure can be lacquered as the client prefers, in the same color of the wall or using a different color.





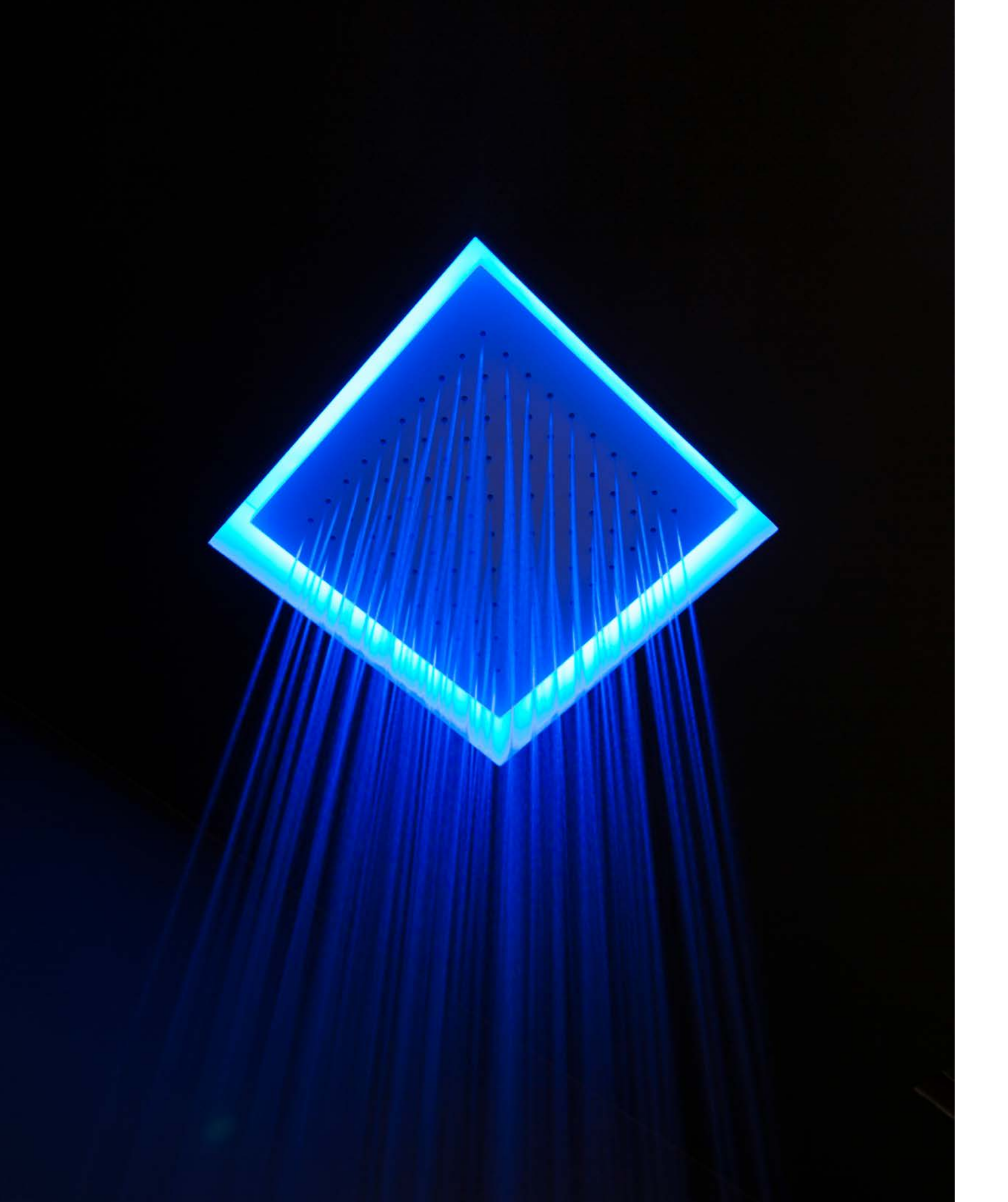

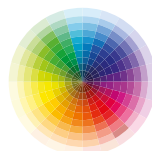

Tutti i soffioni con illuminazione a LED RGB sono dotati di telecomando waterproof IP66 che può essere utilizzato comodamente sotto la doccia.



All overhead showers with RGB LED lighting come with an IP66 waterproof remote control that can easily be used under the shower.

H	P	L	art.
9	35	35	FMS10

Soffione a soffitto con struttura esterna in acciaio AISI 304, disponibile in diverse finiture, con possibile illuminazione a LED RGB comprensiva di telecomando waterproof.

Ceiling mounted showerhead with external frame in steel AISI 304 available in various finishes, with possible RGB LED lighting and waterproof remote.

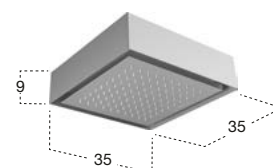

FUORIMETEO SLIM

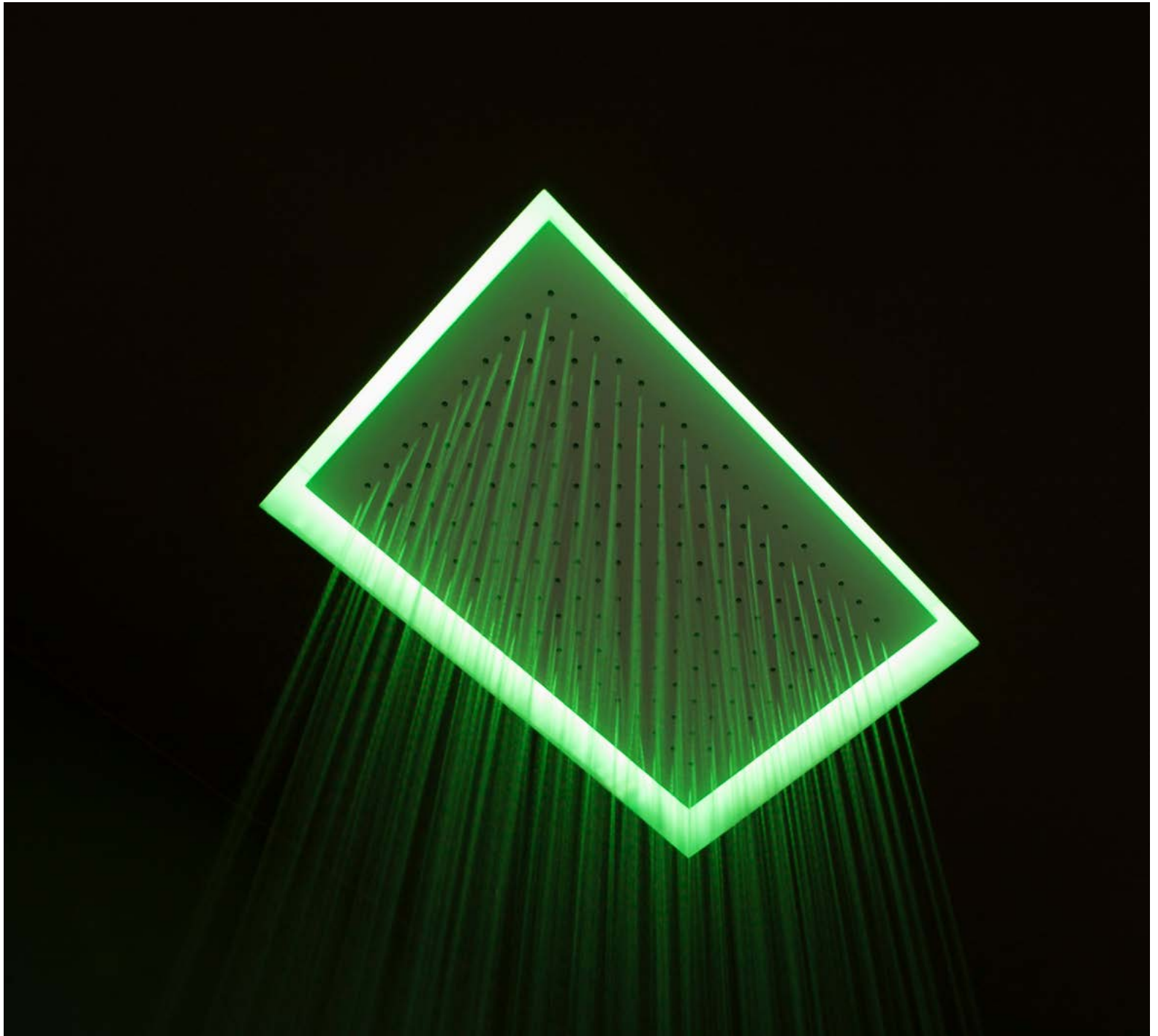

Tutti i soffioni con illuminazione a LED RGB sono dotati di telecomando waterproof IP66 che può essere utilizzato comodamente sotto la doccia.

All overhead showers with RGB LED lighting come with an IP66 waterproof remote control that can easily be used under the shower.

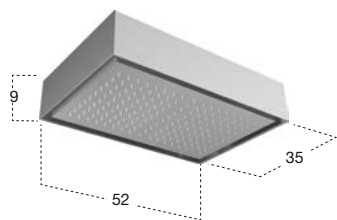
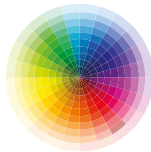

H	P	L	art.
9	35	52	FMS20

Soffione a soffitto con struttura esterna in acciaio AISI 304, disponibile in diverse finiture, con possibile illuminazione a LED RGB comprensiva di telecomando waterproof.

Ceiling mounted showerhead with external frame in steel AISI 304 available in various finishes, with possible RGB LED lighting and waterproof remote.

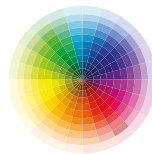

Tutti i soffioni con illuminazione a LED RGB sono dotati di telecomando waterproof IP66 che può essere utilizzato comodamente sotto la doccia.



All overhead showers with RGB LED lighting come with an IP66 waterproof remote control that can easily be used under the shower.

H	P	L	art.
9	35	52	FMS20C

Soffione a soffitto con doccia centrale, cascata e struttura esterna in acciaio AISI 304, disponibile in diverse finiture, con possibile illuminazione a LED RGB comprensiva di telecomando waterproof.

N.B. Necessita di deviatore a due vie.

Ceiling mounted showerhead with central shower, waterfall and external frame in steel AISI 304, available in various finishes, with possible RGB LED lighting and waterproof remote. P.S. Requires two way diverter.

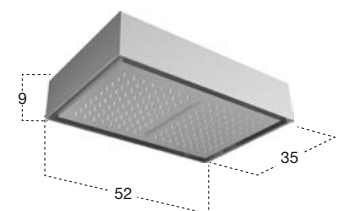

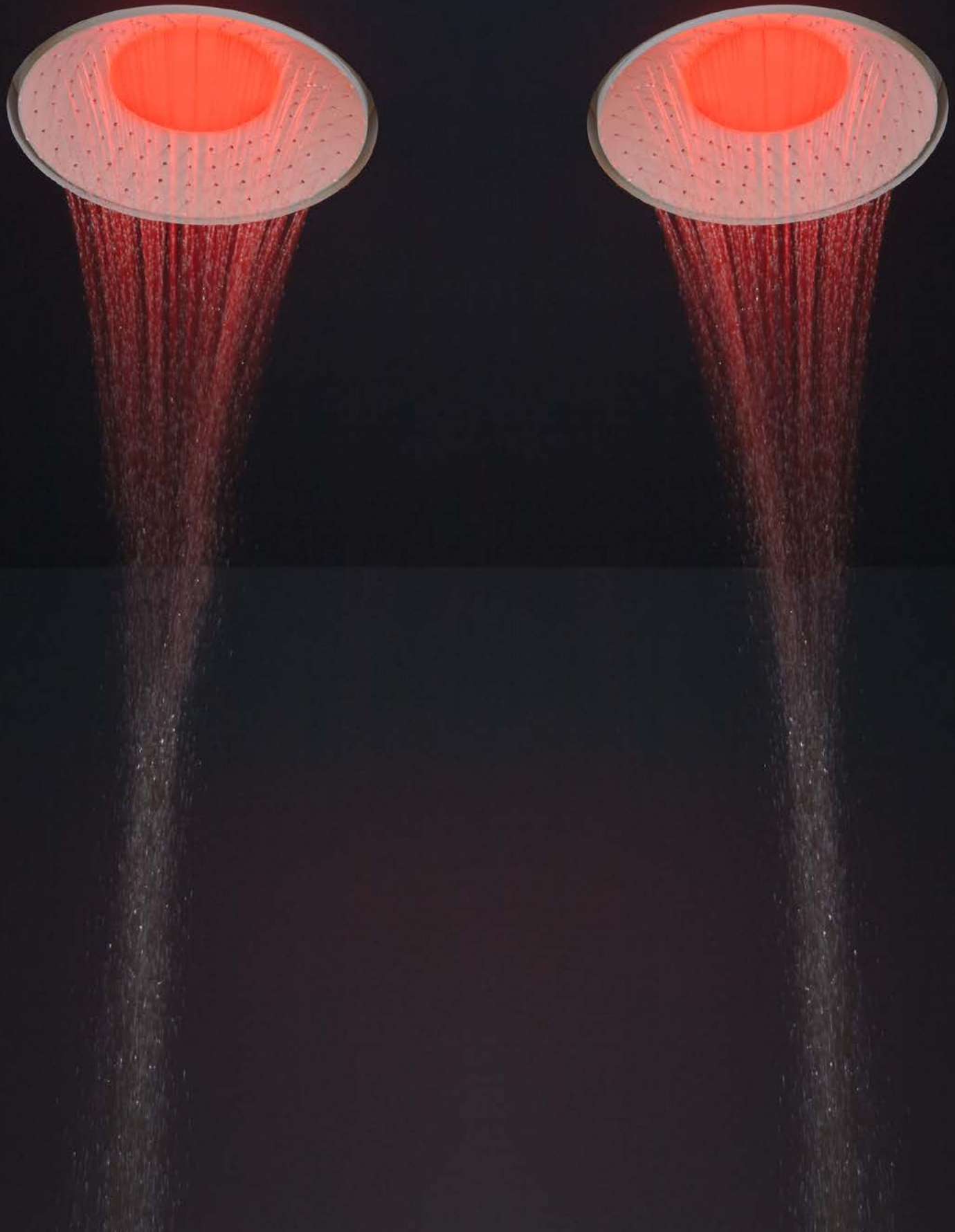

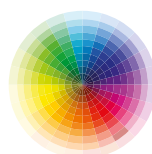
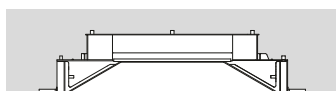

Tutti i soffioni con illuminazione a LED RGB sono dotati di telecomando waterproof IP66 che può essere utilizzato comodamente sotto la doccia.



All overhead showers with RGB LED lighting come with an IP66 waterproof remote control that can easily be used under the shower.

H	P	L	art.
12	54	54	LUMEN

Struttura ad incasso a soffitto in acciaio AISI 304 verniciato bianco con illuminazione a LED RGB comprensivo di telecomando waterproof.

Ceiling encased structure in AISI 304 lacquered white with LED RGB lighting complete with waterproof remote control.

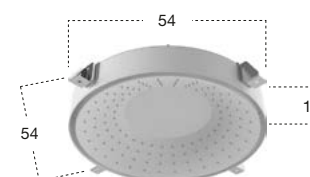

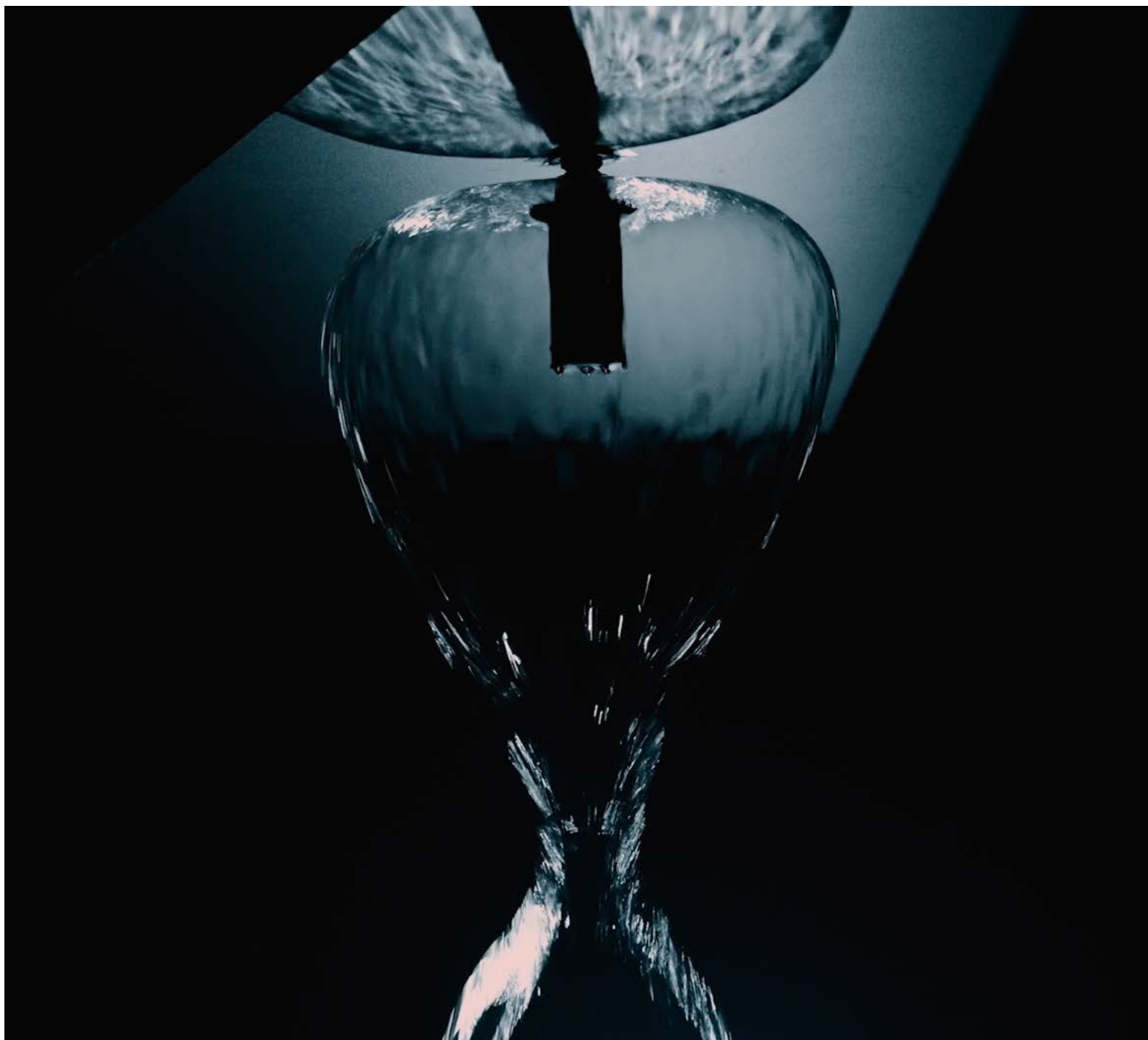

H	Ø	art.
11,5	6	KOSMO

Soffione a soffitto in acciaio inox satinato AISI 304 e Delrin nero.

Ceiling shower in satin stainless steel AISI 304 and black Delrin.



MINIAZIMUT design GI-RA

Modello e design registrato, brevetto depositato

Registered model and design, patent filed

Un cilindro perfetto, essenziale, preciso, oggi disponibile anche nella versione ridotta, con dimensioni ancora più compatte. Una forma che rimanda immediatamente ad altre funzioni, un'immagine che è la perfetta sintesi di tecnologia e design: MiniAzimuth è l'evoluzione di Azimuth, il soffione a soffitto e a parete che rimanda all'immagine di un proiettore luminoso che emette al posto della luce, l'energia vitale dell'acqua. Nel solco di quanto sta avvenendo nel mondo dell'illuminazione con la miniaturizzazione delle sorgenti e la conseguente riduzione delle dimensioni dei corpi, anche Azimuth si restringe e diventa MiniAzimuth, anch'esso disponibile nelle finiture Acciaio Inox Satinato o Grafite oltre che in alcune parti in Delrin nero. Un soffione che ha nello snodo speciale il cuore del progetto, un dettaglio tecnico che diventa estetico, un concept che mette la funzionalità evoluta al primo posto. Lo snodo permette infatti al soffione di ruotare e quindi orientare il getto d'acqua per più di 180° rispetto a un asse. Una caratteristica che ne moltiplica le possibilità d'utilizzo garantendo una maggiore flessibilità di installazione. Azimuth si può applicare a parete o a soffitto a seconda delle esigenze ed è in grado di orientare il getto d'acqua in base alle caratteristiche fisiche dell'utente per garantire il massimo relax. Lo snodo è stato realizzato con una cremagliera che genera un piacevole effetto a scatto e allo stesso tempo permette di tenere fermo il soffione nella posizione desiderata.

A perfect, essential, precise cylinder, now also available in the reduced version with even more compact dimensions. A form that immediately refers to other functions, an image that is the perfect synthesis of technology and design: MiniAzimuth is the evolution of Azimuth, the ceiling and wall showerhead that refers to the image of a luminous projector that emits, instead of light, the vital energy of water. In the wake of what is happening in the lighting world with the miniaturization of the sources and the consequent reduction in body size, Azimuth also shrinks and becomes MiniAzimuth, available in Satin Stainless Steel or Graphite finishes and some parts in black Delrin. A showerhead that has the heart of the project in its special joint, a technical detail that becomes aesthetic, a concept that puts evolved functionality in first place. In fact, the joint allows the showerhead to rotate and then orient the jet of water by more than 180° with respect to an axis. A feature that multiplies the possibilities of use ensuring greater flexibility of installation. Azimuth can be applied to the wall or ceiling according to the needs and is able to direct the jet of water according to the physical characteristics of the user to ensure maximum relaxation. The joint has been made with a rack that generates a pleasant snap effect and at the same time allows to hold the showerhead in the desired position.

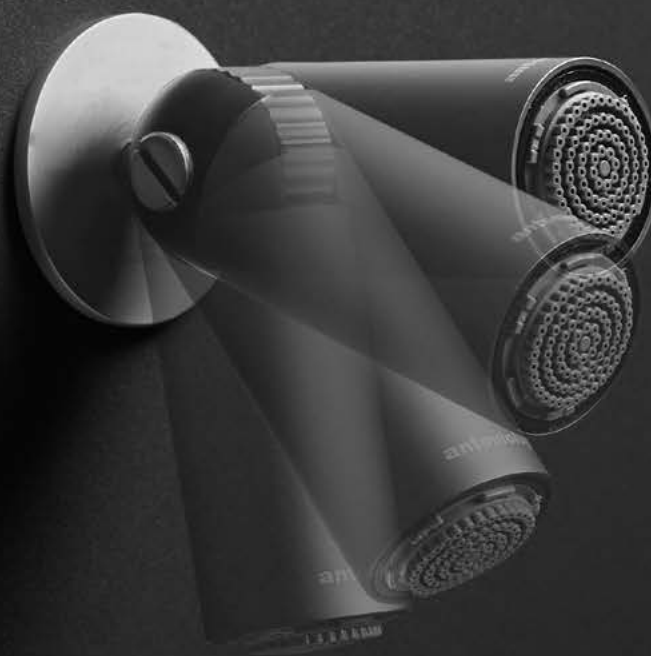



inox satinato

satin stainless steel





MINIAZIMUT



grafite

graphite

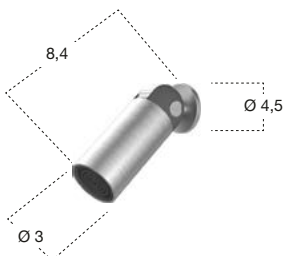

H	P	Ø	art.
4,5	8,4	3	MINIAZIMUT

Soffione a parete o a soffitto in acciaio inox AISI 304 e Delrin nero, con regolazione del getto, disponibile anche in finitura grafite.

Wall or ceiling showerhead in stainless steel AISI 304 and black Delrin, with jet regulation, also available in graphite finish.



grafite
graphite

H	P	L	art.
8	6,8	6,5	VIBRO

Doccetta in acciaio inox satinato AISI 316/L, completa di supporto e presa d'acqua a parete con flessibile 150 cm, disponibile anche in finitura grafite.

Satin stainless steel AISI 316/L, hand shower complete with wall mounted support, water outlet and flexible hose 150 cm, also available in graphite finish.

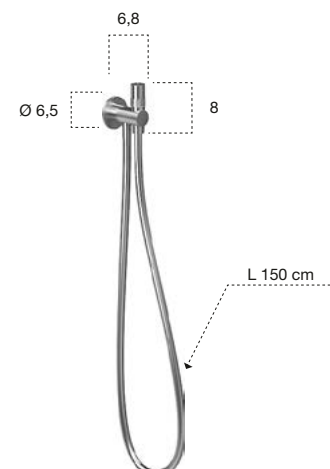

MINIMAYDAY design GI-RA

Modello e design registrato, brevetto depositato
Registered model and design, patent filed

Dal fratello maggiore ha preso l'immagine ironica e divertente, l'immediatezza del gesto, la capacità di dare gioia e colore allo spazio doccia, pur con dimensioni più contenute. La manopola esterna di MiniMayDay ha infatti un diametro di due centimetri inferiore rispetto a quella di MayDay (6 cm contro 8 cm) ma conserva intatte le caratteristiche del progetto originale. Un miscelatore monocomando a parete remoto adattabile a più utenze, rubinetto lavabo, soffione, doccia, che nasce dal ribaltamento di significato che trasforma un pulsante d'emergenza in un comando da utilizzare tutti i giorni, come sottolinea il nome stesso. Rimane invariata la modalità smart di funzionamento. L'acqua si apre grazie a un movimento assiale, non come ci si aspetterebbe premendo il pulsante ma tirandolo verso di noi. La miscelazione del getto d'acqua avviene ruotandolo a dx e sx il pulsante mentre, per chiudere il getto basta premere il pulsante. Come MayDay anche MiniMayDay propone una finitura in Acciaio Inox Satinato con manopole coordinate nella stessa finitura, oppure in grafite, verniciate rosse o bianche.

Ironic and funny image taken from its big brother, the out rightness of the gesture, the ability to give joy and color to the shower space even with smaller dimensions. The external knob of MiniMayDay has in fact a diameter of two centimeters less than that of MayDay (6 cm against 8 cm) but retains intact the characteristics of the original design. A single-lever wall-mounted mixer suitable for multiple usage, sink faucet, showerhead, hand shower, which arises from the overturning of the meaning to transform an emergency button into a command handle used every day, as the name underlines. The smart mode of operation remains unchanged. The water opens thanks to an axial movement, not as you would expect by pressing the button but by pulling it towards us. The mixing of the water jet is done by turning the button to the right and left while, to close the jet, just press the button. Like MayDay, MiniMayDay offers a satin stainless steel finish with coordinated knob, or in graphite, lacquered red or white.



H	P	Ø	art.
10	12	6	MINIMAYDAY

Miscelatore monocomando da incasso a parete, con manopola in acciaio inox satinato oppure in ottone finitura grafite, verniciato rosso o bianco completo di corpo ad incasso.

Single lever mixer with a satin stainless steel handle or graphite, lacquered red or white brass complete with concealed valve.

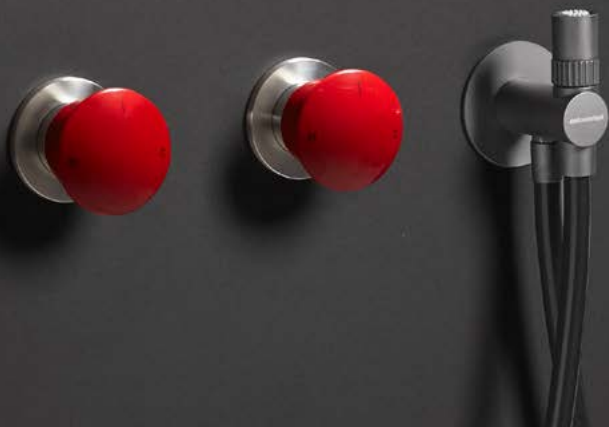

verniciato rosso

red lacquered



verniciato bianco

white lacquered



grafite

graphite



inox satinato

satin stainless steel





H	P	Ø	art.
9,3	13,8	6	MINIMAYDAYD Per / For art. MINIMAYDAY
9,3	13,8	7,9	MAYDAYD Per / For art. MAYDAY

Deviatore da 2, 3, 4 o 5 vie, da incasso a parete in acciaio inox satinato AISI 316/L, completo di corpo ad incasso.

Encased from 2, 3, 4 or 5 way diverter, in satin stainless steel AISI 316/L, complete with concealed valve.



FILTRO, FILO design GI-RA

La prima è tonda e i fori sulla superficie rimandano immediatamente all'immagine di un filtro, la seconda è un minicilindro, dritto, perfetto, che completa idealmente il tracciato generato dal tubo flessibile. Filtro e Filo sono le nuove doccette grazie alle quali antoniolupi prosegue nel percorso di ridefinizione di questo elemento funzionale. Dopo aver ridisegnato con le precedenti collezioni l'archetipo di questo oggetto, le nuove proposte ne enfatizzano la presenza con eleganza e rigore, integrandolo allo stile di tutti gli accessori. Il flessibile interamente in silicone e disponibile nei colori Nero, Bianco e Grigio, disegna sulla superficie un motivo sinuoso che diventa un "decoro mobile". Dopo l'utilizzo infatti, la doccetta può essere riposizionata in un incastro laterale o in alternativa appoggiata sopra il supporto. Alle valenze estetiche le doccette associano le straordinarie qualità dei materiali utilizzati che conferiscono igienicità e garantiscono un getto potente e preciso.

The first is round and the holes on the surface immediately refer to the image of a filter, the second is a mini cylinder, straight, perfect, which ideally completes the path generated by the flexible tube. Filter and Filo are the new handshowers thanks to which antoniolupi continues in the path of redefining this functional element. After redesigning the archetype of this object with the previous collections, the new proposals emphasize its presence with elegance and rigor, integrating it with the style of all the accessories. The all-silicone hose, available in Black, White and Grey, draws a sinuous pattern on the surface that becomes a "floating decoration". After use, in fact, the shower can be repositioned in a lateral joint or alternatively resting on the support. To the aesthetic values, the showers combine the extraordinary qualities of the materials used that give cleanliness and guarantee a powerful and precise jet.





FILTRO





FILTRO

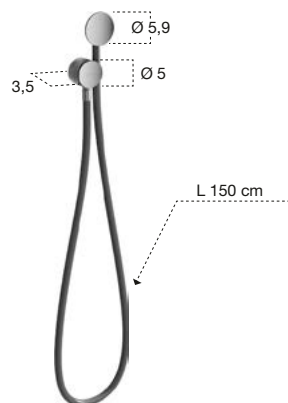

H	P	L	art.
5,9	3,5	5	FILTRO

Doccetta in acciaio inox satinato, lucido o grafite completa di supporto e presa d'acqua a parete con flessibile 150 cm in silicone colorato bianco, nero o grigio.

Hand shower in satin or polished stainless steel or graphite finish complete with wall support and water outlet, flexible hose 150 cm in silicone colored white, black or grey.



H	P	L	art.
8,4	3,5	5	FILO

Doccetta in acciaio inox satinato, lucido o grafite completa di supporto e presa d'acqua a parete con flessibile 150 cm in silicone colorato bianco, nero o grigio.

Hand shower in satin or polished stainless steel or graphite finish complete with wall support and water outlet, flexible hose 150 cm in silicone colored white, black or grey.

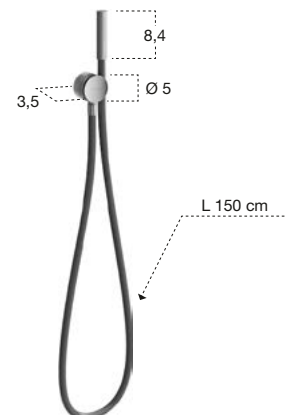



Compatto ma slanciato allo stesso tempo, leggero e dinamico come un piccolo uccello che si posa delicatamente sulla superficie del piano o al contrario stà per spiccare il volo. Come un piccolo colibrì il rubinetto Indigo porta in sé un'energia concentrata in poco spazio, pronta a sprigionarsi una volta aperto il getto d'acqua.

Compact yet slender, light and dynamic like a small bird that sits gently or on the contrary is about to take flight. Like a small hummingbird, the Indigo tap carries within itself an energy concentrated in a small area, ready to release itself once the water has been opened.



grafite

graphite

INDIGO





grafite

graphite

INDIGO





grafite

graphite

INDIGO





grafite

graphite





grafite

graphite

INDIGO





grafite

graphite

INDIGO



grafite

graphite





cromo lucido
polished chrome



acciaio satinato
satin stainless steel





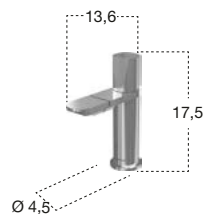

H	P	Ø	art.	
17,5	13,6	4,5	ND400LU	Cromo Lucido / Polished Chrome
	13,6	4,5	ND400SA	Acciaio Satinato / Satin Stainless Steel
	13,6	4,5	ND400GR	Grafite / Graphite

Miscelatore monocomando per bidet.

Single lever mixer for bidet.

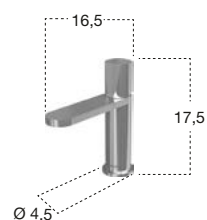

H	P	Ø	art.	
17,5	16,5	4,5	ND301LU	Cromo Lucido / Polished Chrome
	16,5	4,5	ND301SA	Acciaio Satinato / Satin Stainless Steel
	16,5	4,5	ND301GR	Grafite / Graphite

Miscelatore monocomando da piano per lavabo.

Single lever basin mixer for top mounting.



H	P	Ø	art.	
28,5	19,5	4,5	ND303LU	Cromo Lucido / Polished Chrome
	19,5	4,5	ND303SA	Acciaio Satinato / Satin Stainless Steel
	19,5	4,5	ND303GR	Grafite / Graphite

Miscelatore monocomando da piano per lavabo.

Single lever basin mixer for top mounting



H	P	Ø	art.	
38,5	19,5	4,5	ND304LU	Cromo Lucido / Polished Chrome
	19,5	4,5	ND304SA	Acciaio Satinato / Satin Stainless Steel
	19,5	4,5	ND304GR	Grafite / Graphite

Miscelatore monocomando da piano per lavabo.

Single lever basin mixer for top mounting

art.
ND902IN

Corpo ad incasso per art. ND901LU, art. ND901SA, art. ND901GR, art. ND902LU, art. ND902SA, art. ND902GR, art. ND903LU, art. ND903SA e art. ND903GR.

Concealed valve for art. ND901LU, art. ND901SA, art. ND901GR, art. ND902LU, art. ND902SA, art. ND902GR, art. ND903LU, art. ND903SA and art. ND903GR.

H	P	Ø	art.	
101	29	10	ND901LU	Cromo Lucido / Polished Chrome
	29	10	ND901SA	Acciaio Satinato / Satin Stainless Steel
	29	10	ND901GR	Grafite / Graphite
106	33,5	10	ND902LU	Cromo Lucido / Polished Chrome
	33,5	10	ND902SA	Acciaio Satinato / Satin Stainless Steel
	33,5	10	ND902GR	Grafite / Graphite

Miscelatore monocomando da terra per lavabo, escluso di corpo ad incasso.

Freestanding single lever sink mixer, concealed valve not included.

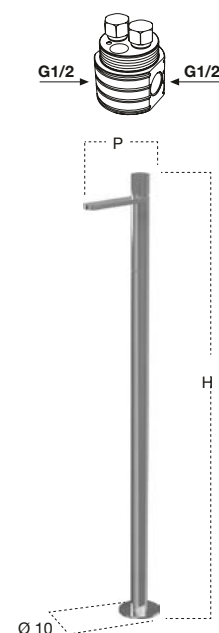

art.
ND201INLU Cromo lucido / Polished Chrome
ND201INSA Acciaio Satinato / Satin Stainless Steel
ND201INGR Grafite / Graphite

Corpo ad incasso per art. ND200LU, art. ND200SA, art. ND200GR, art. ND201LU, art. ND201SA e art. ND201GR.

Concealed valve for art. ND200LU, art. ND200SA, art. ND200GR, art. ND201LU, art. ND201SA and art. ND201GR.

H	P	L	art.	
7	17	20	ND200LU	Cromo Lucido / Polished Chrome
	17	20	ND200SA	Acciaio Satinato / Satin Stainless Steel
	17	20	ND200GR	Grafite / Graphite
26	20	20	ND201LU	Cromo Lucido / Polished Chrome
	26	20	ND201SA	Acciaio Satinato / Satin Stainless Steel
	26	20	ND201GR	Grafite / Graphite

Miscelatore monocomando a parete per lavabo, escluso di corpo ad incasso.

Single lever wall mount sink mixer, concealed valve not included.

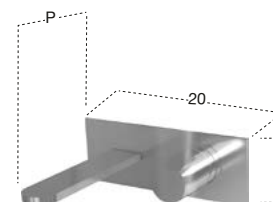
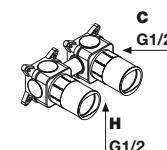

P	Ø	art.	
20	7	ND921LU	Cromo Lucido / Polished Chrome
	7	ND921SA	Acciaio Satinato / Satin Stainless Steel
	7	ND921GR	Grafite / Graphite
25	7	ND922LU	Cromo Lucido / Polished Chrome
	7	ND922SA	Acciaio Satinato / Satin Stainless Steel
	7	ND922GR	Grafite / Graphite

Erogatore a parete per lavabo, completo di corpo ad incasso.

Wall mount sink spout complete with concealed valve.

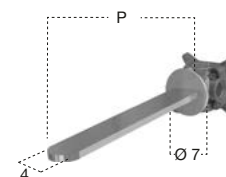

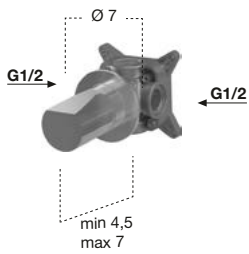

H	P	Ø	art.	
6,8	4,5/7	7	ND605LU	Cromo Lucido / Polished Chrome
	4,5/7	7	ND605SA	Acciaio Satinato / Satin Stainless Steel
	4,5/7	7	ND605GR	Grafite / Graphite

Rubinetto da arresto acqua calda e fredda con vitone ceramico 90°, completo di corpo ad incasso.

Hot and cold water stop valve with 90° ceramic head, complete with concealed valve.

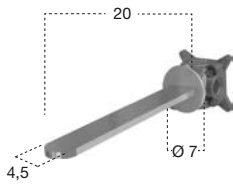

P	Ø	art.	
20	7	ND704LU	Cromo Lucido / Polished Chrome
20	7	ND704SA	Acciaio Satinato / Satin Stainless Steel
20	7	ND704GR	Grafite / Graphite

Erogatore a parete per vasca completo di corpo ad incasso.

Bathtub wall spout complete with concealed valve.

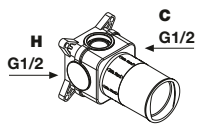

	art.	
	ND601INLU	Cromo Lucido / Polished Chrome
	ND601INSA	Acciaio Satinato / Satin Stainless Steel
	ND601INGR	Grafite / Graphite

Corpo ad incasso per Art. ND601LU, Art. ND601SA e Art. ND601GR.

Concealed valve for Art. ND601LU, Art. ND601SA and Art. ND601GR.

P	Ø	art.	
4,5/7	7	ND601LU	Cromo Lucido / Polished Chrome
4,5/7	7	ND601SA	Acciaio Satinato / Satin Stainless Steel
4,5/7	7	ND601GR	Grafite / Graphite

Miscelatore monocomando da incasso a parete, escluso di corpo ad incasso.

Encased wall mixer, concealed valve not included.

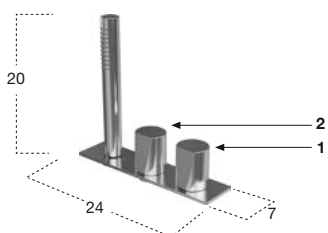

H	P	L	art.	
20	7	24	ND702LU	Cromo Lucido / Polished Chrome
	7	24	ND702SA	Acciaio Satinato / Satin Stainless Steel
	7	24	ND702GR	Grafite / Graphite

Gruppo bordo vasca completo di miscelatore acqua calda e fredda (1), miscelatore per doccia (2) e doccia con flessibile 150 cm a scomparsa.

Bath rim set complete with hot and cold water mixer (1), mixer for hand shower (2) and hand shower with hidden hose 150 cm.

art.

ND902IN

Corpo ad incasso per Art. ND901LU, Art. ND901SA, Art. ND901GR, Art. ND902LU, Art. ND902SA, Art. ND902GR, Art. ND903LU, Art. ND903SA e Art. ND903GR.

Concealed valve for Art. ND901LU, Art. ND901SA, Art. ND901GR, Art. ND902LU, Art. ND902SA, Art. ND902GR, Art. ND903LU, Art. ND903SA and Art. ND903GR.

H	P	Ø	art.	
86	28,5	10	ND903LU	Cromo Lucido / Polished Chrome
	28,5	10	ND903SA	Acciaio Satinato / Satin Stainless Steel
	28,5	10	ND903GR	Grafite / Graphite

Colonna da terra per vasca, completa di miscelatore per erogazione (1), miscelatore per doccia (2), supporto con chiusura integrata di sicurezza (3) e doccia con flessibile 150 cm, escluso di corpo ad incasso.

Freestanding bath mixer, complete with mixer for spout (1), hand shower mixer (2) support with integrated closure for security (3) and hand shower with flexible hose 150 cm, concealed valve not included.

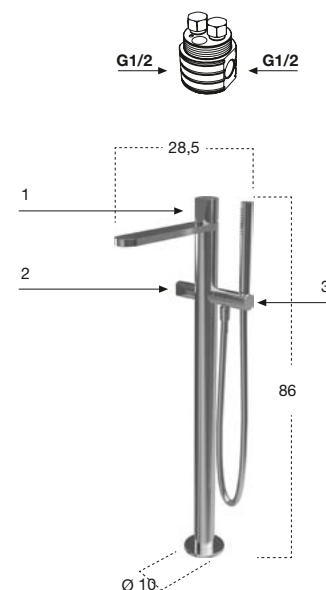

art.

ND602INLU Cromo Lucido / Polished Chrome

ND602INSA Acciaio Satinato / Satin Stainless Steel

ND602INGR Grafite / Graphite

Corpo ad incasso per Art. ND602LU, Art. ND602SA e Art. ND602GR.

Concealed valve for Art. ND602LU, ND602SA and Art. ND602GR.

P	Ø	art.	
4,5/7	7	ND602LU	Cromo Lucido / Polished Chrome
4,5/7	7	ND602SA	Acciaio Satinato / Satin Stainless Steel
4,5/7	7	ND602GR	Grafite / Graphite

Deviatore incasso a due vie, escluso di corpo ad incasso.

Encased two way diverter, concealed valve not included.

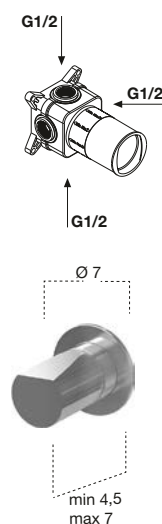

art.

ND603INLU Cromo Lucido / Polished Chrome

ND603INSA Acciaio Satinato / Satin Stainless Steel

ND603INGR Grafite / Graphite

Corpo ad incasso per Art. ND603LU, Art. ND603SA e Art. ND603GR.

Concealed valve for Art. ND603LU, Art. ND603SA and Art. ND603GR.

P	Ø	art.	
4,5/7	7	ND603LU	Cromo Lucido / Polished Chrome
4,5/7	7	ND603SA	Acciaio Satinato / Satin Stainless Steel
4,5/7	7	ND603GR	Grafite / Graphite

Deviatore incasso a tre vie, escluso di corpo ad incasso.

Encased three way diverter, concealed valve not included.

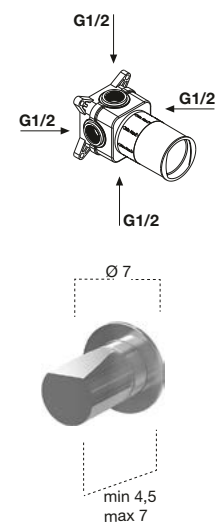



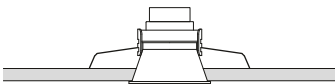

H	Ø	art.
10	8	ZENITLED

Lampada con struttura ad incasso a soffitto in alluminio nero e illuminazione a led.

Lamp with ceiling encasing structure in black aluminum and led lighting.





illuminazione a LED 4000 K. Su richiesta illuminazione a LED 3000 K senza maggiorazione di prezzo.

LED lighting 4000 K. Upon request LED lighting 3000 K available without additional surcharge.

P	L	H	art.
2,5	da / from 54 a / to 216	50	ORMA50W
2,5	da / from 54 a / to 216	75	ORMA75W
2,5	da / from 54 a / to 216	90	ORMA90W
2,5	da / from 54 a / to 216	110	ORMA110W

Specchio spess. 4 mm a filo lucido con angoli stondati e illuminazione a led luce bianca.

Polished edge mirror 4 mm thick with rounded corners and white led lighting.

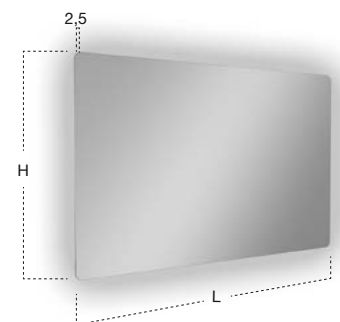





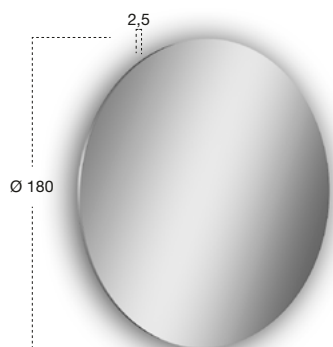

illuminazione a LED 4000 K. Su richiesta illuminazione a LED 3000 K senza maggiorazione di prezzo.

LED lighting 4000 K. Upon request LED lighting 3000 K available without additional surcharge.

Ø	P	art.
180	2,5	CIRCUS180W

Specchio spess. 5 mm a filo lucido con illuminazione a led luce bianca, completo di telaio.

Polished edge mirror 5 mm thick with white led lighting, complete with frame.

Ø	P	art.
180	2,5	CIRCUS180

Specchio spess. 5 mm a filo lucido completo di telaio.

Polished edge mirror 5 mm thick complete with frame.



H	art.
50	FOCUS50
75	FOCUS75
90	FOCUS90
100	FOCUS100
110	FOCUS110

Ingranditore 2x completo di piastra magnetica, per specchi Art. VARIO, art. VERTICE e art. FILA.

Magnifying mirror 2x complete with magnetic plate for mirrors Art. VARIO, art. VERTICE and art. FILA.

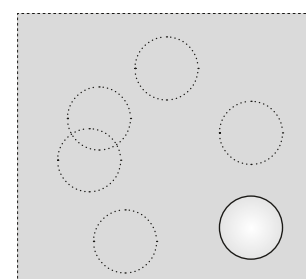
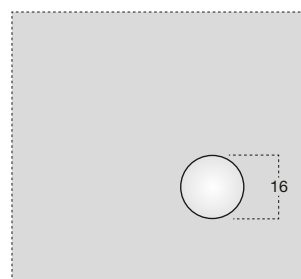

Ø	P	art.
16	1,2	FOCUS

Secondo ingranditore 2x.

Second magnifying mirror 2x.

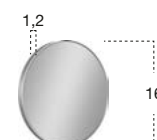



Illuminazione a LED 4000 K. Su richiesta illuminazione a LED 3000 K senza maggiorazione di prezzo.

LED lighting 4000 K. Upon request LED lighting 3000 K available without additional surcharge.

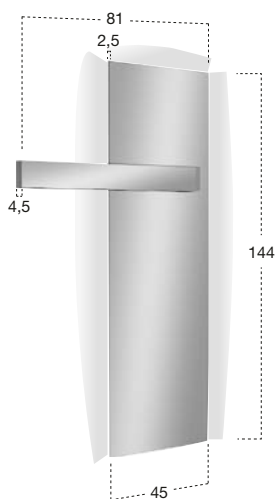

Versione sx

Left version

176

H	L	art.
144	45 (L 81)	NEULUCE1

Specchio spess. 5 mm a filo lucido con illuminazione a led luce bianca, completo di telaio e lampada LUCENTE versione dx o sx.

Polished edge mirror 5 mm thick with white led lighting complete with frame and lamp LUCENTE, right or left hand version.



Illuminazione a LED 4000 K. Su richiesta illuminazione a LED 3000 K senza maggiorazione di prezzo.

LED lighting 4000 K. Upon request LED lighting 3000 K available without additional surcharge.

Ø	art.
90 (L 112,5)	CIRCUS190W
108 (L 135)	CIRCUS1108W

Specchio spess. 5 mm a filo lucido con illuminazione a led luce bianca, completo di telaio e lampada LUCENTE versione dx o sx.

Polished edge mirror 5 mm thick with white led lighting, complete with frame and lamp art. LUCENTE, right or left hand version.

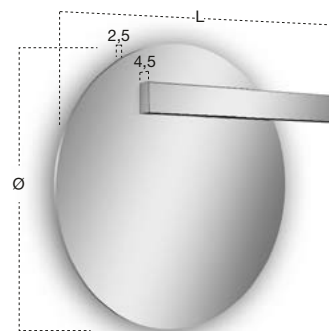

Versione dx

Right version



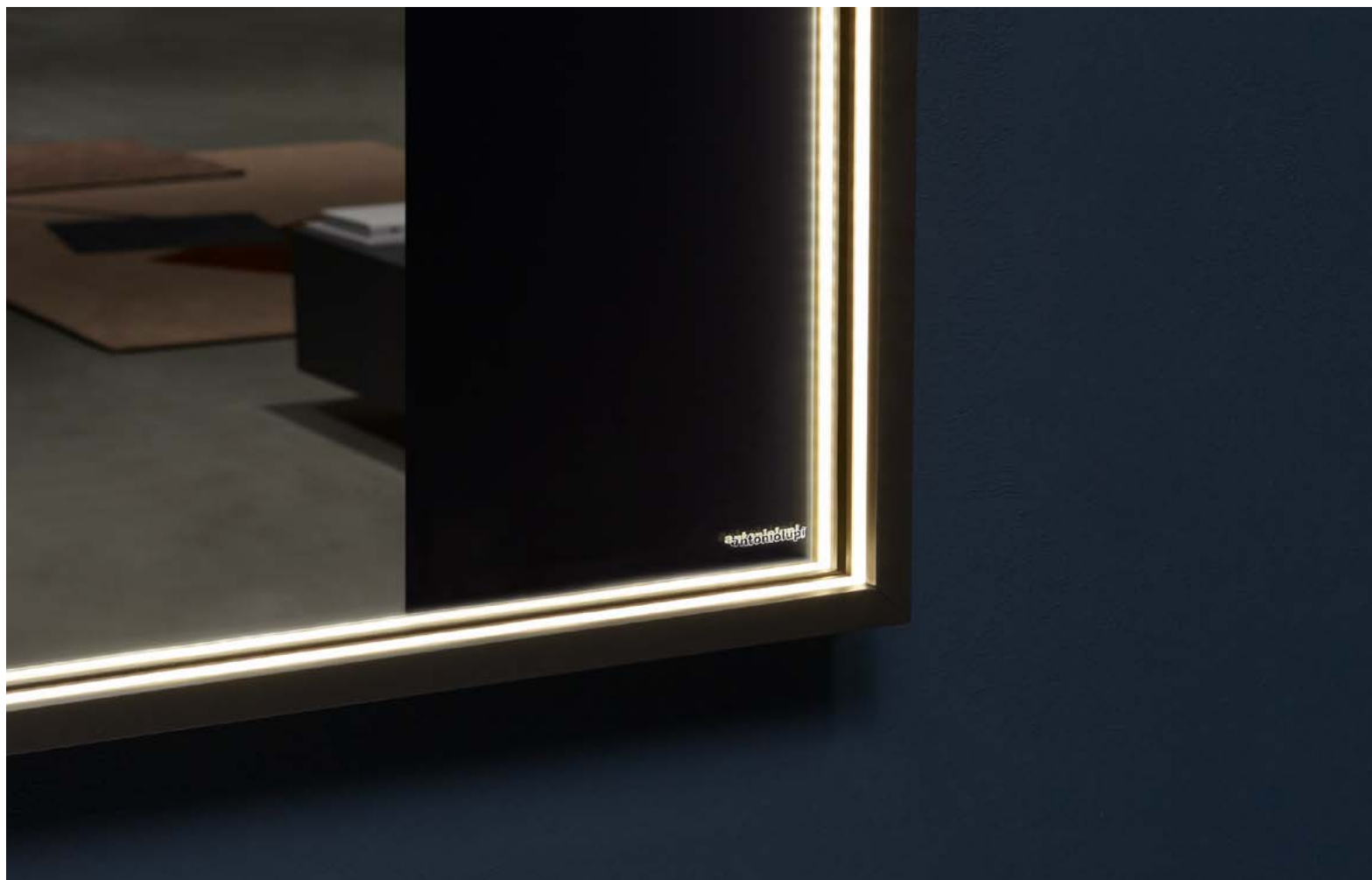

Come un quadro, un'opera d'arte, un segno rigoroso che nasce da una geometria perfetta e racchiude una o più immagini in movimento. Un perimetro preciso ma allo stesso tempo capace di suscitare emozione e sorpresa. È elegante e raffinata la cornice in alluminio finitura bronzo, che caratterizza lo specchio Edison. La luce integrata nella cornice è l'assoluta protagonista di questo sistema e definisce una delle aree più importanti della stanza da bagno conferendogli raffinatezza e fascino. Edison è disponibile in diverse dimensioni e quando è acceso conferisce un'aura magica a tutto l'ambiente.

Like a painting, a work of art, a rigorous sign that comes from perfect geometry and contains one or more moving images. A precise perimeter but at the same time capable of arousing emotion and surprise. The bronze finish aluminum frame, which characterizes the Edison mirror, is elegant and refined. The light integrated into the frame is the absolute protagonist of this system and defines one of the most important areas of the bathroom giving it refinement and charm. Edison is available in different sizes and when lit it gives a magical aura to the entire environment.

Illuminazione a LED 4000 K. Su richiesta illuminazione a LED 3000 K senza maggiorazione di prezzo.

LED lighting 4000 K. Upon request LED lighting 3000 K available without additional surcharge.

P	L	H	art.
5,4	da / from 54 a / to 216	50	EDISON50W
5,4	da / from 54 a / to 216	75	EDISON75W

Specchio spess. 4 mm a filo lucido orizzontale o verticale con cornice in alluminio finitura bronzo con illuminazione a led luce bianca.

Horizontal or vertical mirror 4 mm thick with bronze aluminum frame and white led lighting.

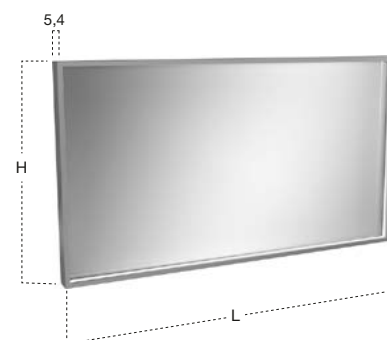

RAPIDO design GI-RA

Essenziale, rigoroso, pulito nel suo minimalismo assoluto per integrarsi alla perfezione dal punto di vista stilistico con gli altri accessori che compongono l'ambiente bagno contemporaneo di antoniolupi. Una presenza discreta ma elegante allo stesso tempo, un oggetto funzionale che diventa un elemento della composizione. Materia e geometria sono protagoniste del nuovo scopino Rapido disegnato da GI-RA Design. Una perfetta forma cilindrica in acciaio inox satinato nella quale si inserisce un'asta sottile, sempre in acciaio con l'inedita spatola in silicone che garantisce la massima igiene oltre che conferire una forma slanciata all'insieme. Un coordinamento materico assoluto, un segno chiaro e lineare per un oggetto flessibile che può essere posizionato a terra o sospeso per amplificare la funzionalità.

Essential, rigorous, clean in its absolute minimalism to integrate perfectly from the stylistic point of view with the other accessories that make up the contemporary bathroom of antoniolupi. A discreet but elegant presence at the same time, a functional object that becomes an element of the composition. Matter and geometry are the protagonists of the new Rapido brush designed by GI-RA Design. A perfect cylindrical shape in satin stainless steel in which inserted is a thin steel rod with the new silicone spatula that guarantees maximum hygiene as well as giving a slender shape. An absolute coordination of materials, a clear and linear sign for a flexible object that can be placed on the floor or suspended to amplify functionality.









RAPIDO



H	Ø	art.
43,5	8	RAPIDO1

Porta scopino da appoggio in acciaio inox satinato AISI 304.
Freestanding toilet brush and holder in satin stainless steel AISI 304.



H	Ø	art.
43,5	4	RAPIDO2

Porta scopino con supporto a parete in acciaio inox satinato AISI 304.

Wall hanging toilet brush and holder in satin stainless steel AISI 304.





zirconio



titanio



bronzo



champagne

PLAY

Appendi abiti singolo a parete in alluminio in finitura bronzo, titanio, zirconio e champagne.

Single clothes hook in bronze, titanium, zirconium and champagne aluminum finishes.



H	P	L	art.
3	8	6	PLAY106

Porta salviette in alluminio in finitura bronzo, titanio, zirconio e champagne.

Towel holder in bronze, titanium, zirconium and champagne aluminum finishes.

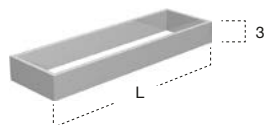

H	P	L	art.
3	8	27	PLAY27
		40	PLAY40
		54	PLAY54
		72	PLAY72

Pianetto in Corian liscio.

Corian surface.



H	P	L	art.
1,2	8	13,5	TAPE1

Pianetto in Corian liscio dx o sx reversibile, con portarotolo in alluminio in finitura bronzo, titanio, zirconio e champagne.

Reversible corian surface with right or left paper roll holder in bronze, titanium, zirconium and champagne aluminum finish.



H	P	L	art.
10	8	13,5	PLAY2

Porta sapone in Corian.

Corian soap dish.



H	P	L	art.
1,2	8	13,5	TAPE3

Porta sapone in Corian dx o sx reversibile, con portarotolo in alluminio in finitura bronzo, titanio, zirconio e champagne.

Reversible right or left Corian soap dish and paper roll holder in bronze, titanium, zirconium and champagne aluminum finishes.



H	P	L	art.
10	8	13,5	PLAY4

Pianetto in Corian liscio.

Corian surface.



H	P	L	art.
1,2	8	27	TAPE11

Pianetto in Corian con griglia.

Gridded Corian surface.



H	P	L	art.
1,2	8	13,5	TAPE6

Pianetto in Corian con griglia.

Gridded Corian surface.



H	P	L	art.
1,2	8	27	TAPE14



bronzo

www.antoniolupi.it

Per essere costantemente informati su novità e prodotti in modo dettagliato, vi invitiamo a navigare nel nostro sito sempre aggiornato. Nell'area download potrete scaricare tutto il materiale tecnico ed informativo che vi necessita.

To constantly be up to date in a detailed manner on novelties and products please navigate through our website. In the download area you can find all the necessary technical information.



Scarica l'App su iTunes e Google Play per entrare nel mondo antoniolupi

Download the App on iTunes and Google Play to discover the world of antoniolupi



Prodotto interamente in Italia.

Entirely made in Italy.

© Antonio Lupi Design S.p.A. 2019

NOTA: alla Antonio Lupi Design S.p.A. è riservata la facoltà di apportare ai propri modelli qualsiasi modifica estetica, tecnica, nelle dimensioni e nei colori, ritenuta necessaria, nonché la facoltà di sospendere la produzione in qualunque momento senza preavviso, rinunziata fin d'ora da parte del committente ogni conseguente richiesta risarcitoria. Si declina ogni responsabilità relativa ad eventuali inesattezze contenute in questo catalogo, se dovute ad errori di stampa o trascrizioni. Nessun contenuto di questo catalogo può essere copiato, riprodotto anche parzialmente, ripubblicato, trasmesso o distribuito in qualunque forma, senza autorizzazione scritta dell'Antonio Lupi Design S.p.a.

NOTE: Antonio Lupi Design S.p.A. reserves the right to make any and all necessary esthetic, technical, colour or size modifications in order to enhance use and esthetic value, and may suspend the production cycle at any moment without notice. Such instances may not be subject to claim by the client. We decline all responsibilities for any possible uncertainties due to misprints in this catalogue. None of the material in this catalogue can be copied, reproduced, republished or distributed in any or partial way unless a written authorization is given from the company Antonio Lupi Design S.p.a.

antoniolupi

73

75

Antonio Lupi Design S.p.A.
via Mazzini 73/75 - 50050 Stabbia
Cerreto Guidi (Firenze) - Italy
T +39 0571 586801-05694
F +39 0571 586885
www.antoniolupi.it
lupi@antoniolupi.it

